

77-TON FLAT

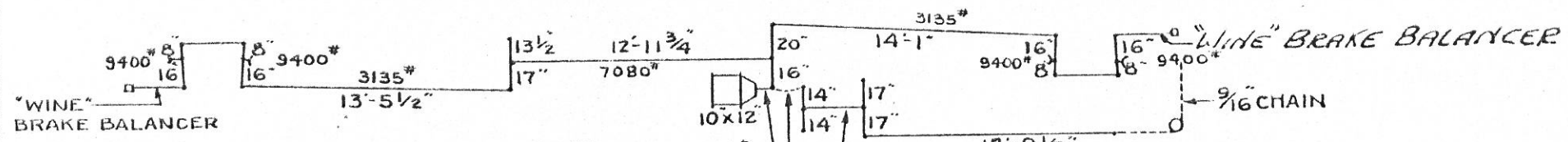
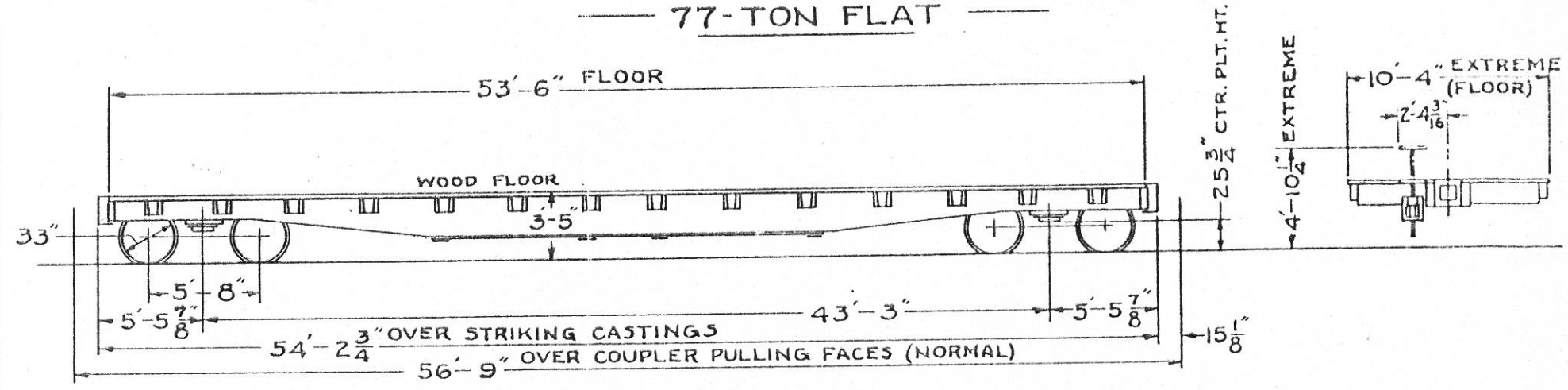

NOTE NO 1 THE FOLLOWING CARS ARE EQUIPPED WITH 8'-0" HIGH BULKHEADS FOR PIPE LOADING.
 FLAT CAR 905 IS 51'-4" BETWEEN BULKHEADS
 " " 928 IS 50'-6" " "
 " " 940 IS 50'-6" " "
 " " 946 IS 50'-6" " "

BRAKE DIAGRAM

GENERAL
 BUILDER:- GREENVILLE STEEL CAR CO.
 YEAR BUILT:- 1942
 BUILDER'S REF:- 00-362.
 A.A.R. CLASS:- FM. OR FMS
 NO. BUILT:- 50
 R.R. SPEC. NO. III
 AVERAGE LT. WT. - 60400
 " LOAD LIMIT:- 159600

BODY
 AIR BRAKE MFG. - N.Y.A.B. Co.
 " SCHEDULE:- AB.
 BODY CENTER PLATE:- 13 3/4" FORGED STEEL.
 " SIDE BEARING:- HARDENED AXLE STEEL.
 CENTER SILL:- BUILT-UP.
 " COVER PLT. - 1/2" x 28"
 " AREA:- (FISH BELLY)
 COUPLER:- "E" 6 1/4 x 8" SLOTTED. BOTTOM OP.
 " RELEASE RIG:- "IMPERIAL" ROTARY.
 DRAFT GEAR:- "MINER" A-22-XB. 2 1/2" TRAVEL.
 " ATTACHMENT:- C.S. YOKE-BUCKEYE

END SILL:- 12" 20.7 LBS. L
 FLOORING:- 2 3/8"
 GENERAL DRAWING:- 18254 DT&I V-1875
 HAND BRAKE:- "EQUIPCO" DROP SHAFT
 SIDE SILL:- BUILT-UP.
 SIDE BEARING CENTERS:- 4'-2"

TRUCK
 BOLSTER:- B.S.C. PATT. No. B-741.
 BRAKE BEAM:- "UNIT" 20000 LBS. CAPY. (NO. 3)
 " SAFETY:- NONE.
 CENTER PLATE:- CAST INTEGRAL WITH BOLSTER
 GENERAL DRAWING:-
 JOURNAL:- 6" x 11"
 " BOX:- INTEGRAL.
 R.R. SPEC. NO. - 112
 SIDE BEARING:- "STUCKI" SPRING STEEL.
 " FRAME:- B.S.C. PATT. NO. F-740
 WITH WASTE RETAINER RIBS -
 SPRINGS; A.A.R. "D-2" - 1 5/8" TRAVEL
 AND "SIMPLEX" SNUBBERS
 TRUCK; DOUBLE TRUSS-"UNIT"

WHEELS:- ONE WEAR WROT STEEL.
 WEIGHT OF BOLSTER:-
 " " SIDE FRAME:-
 " " ONE TRUCK:-

CARS:- 900-949
 D.T. & I.
 MOTIVE POWER DEPT.

REVISION
 9-5712-60 5/62 1/65 5/8/78
 R.N. RN. FAM FR 1/10 1/78

9-1-42

- 114 TON COIL STEEL FLAT -

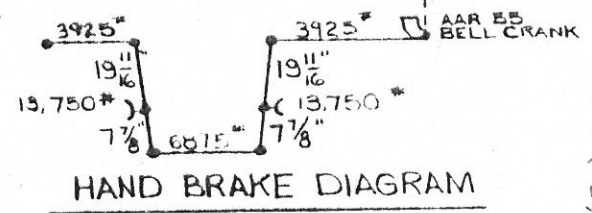
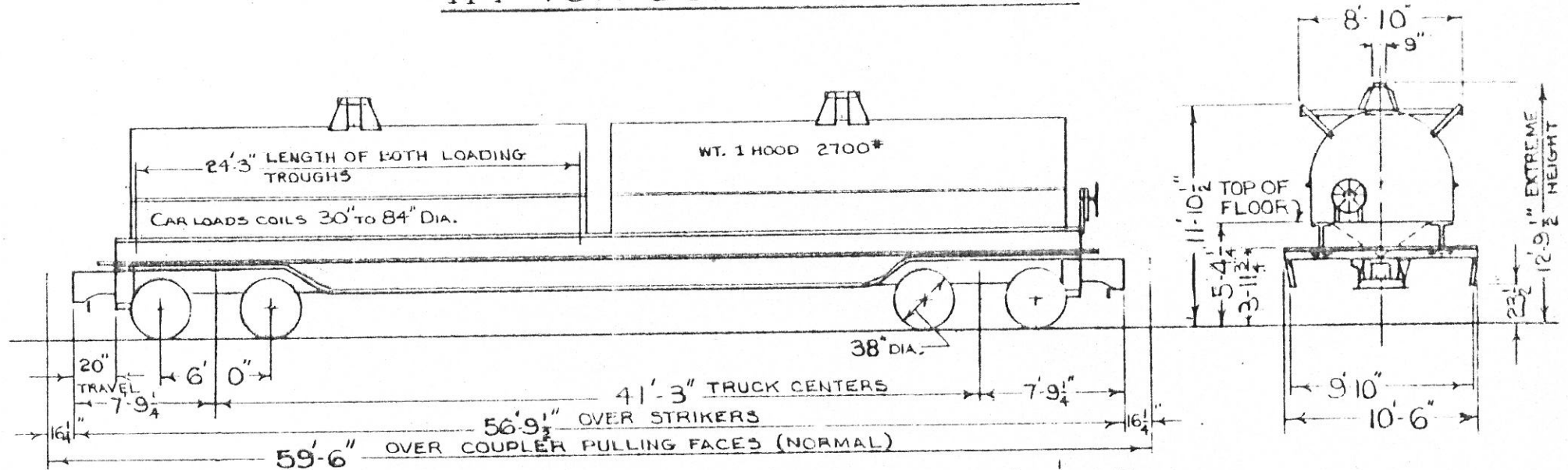

Handwritten notes:
 12' 9 1/2"
 5' 4 1/4"
 7' 5 1/4"

- GENERAL -	DRAFT GEAR: MINER RF-333 (HIGH CAPACITY)	GENERAL DWG: NAT'L CAST. 45894
BUILDER: WHITEHEAD & KALES	DRAFT GEAR ATTACHMENT: GRADE B'CS YOKE (B-Y45)	JOURNALS: 7" x 12" ROLLER BEARING
YEAR BUILT: 1965	END SILL: 12" WF 45# FT BEAM 8 1/4" PLT'S.	JOURNAL BEARINGS: TIMKEN 7" x 12" AP
AAR CLASS: FMS	FLOOR: 3" OAK - 30° SLOPE	JOURNAL BEARING RETAINER: NAT'L CASTING #3135
NO. BUILT: 1	GENERAL DWG: AA229-370- (DT&I V-8190)	SIDE BEARINGS: STUCKI DOUBLE ROLLER (DT&I DWG. 7-5811)
AVE. LT. WT: 85,200 LBS.	HAND BRAKE: UNIVERSAL 7400	SIDE FRAME: NAT'L CASTINGS PATT. NO. 45677-1
AVE. LOAD LIMIT: 229,800 LBS.	RUNNING BOARD: BLAW-KNOX NX-16 GRATING	NARROW PEDESTAL JAW AAR IDENT NO. 983
MIN. RADIUS CURVE: 195 FT.	SIDE BEARING CENTERS: 4'-2"	SPRINGS: 2 1/2" TRAVEL AAR D-5
	SIDE SILL: 26" WF @ 192# FT. BEAM (MODIFIED)	16 OUTER & 16 INNER COILS PER TRUCK
- BODY -		TYPE OF TRUCK: 7" x 12" NATIONAL SUPER C-1
AIR BRAKE MFG.: WESTINGHOUSE		EQUIPPED FOR ROLLER BEARINGS AND
AIR BRAKE SCHEDULE: ABD-1 VALVE WABCO PAC		TRUCK MOUNTED BRAKES
B-4, 9 UNITS, WITH J-1 RELAY VALVE		WHEELS: 38" ONE WEAR WROT STEEL B-38
BODY CENTER PLATE: 15 3/4" FABRICATED		
BODY SIDE BEARING: C-1045 STEEL HEAT TREATED		
TO 260-350 BHN. 4" x 2" x 1/8"		
CENTER SILL: SLIDING: 2 LAHT. 412# FT ZEE		
STATIONARY: NONE		
CENTER SILL AREA: SLIDING - 24.24 SQ. IN.	- TRUCK -	
COUPLER: B-E4942 B-HT TYPE E' HEAD TYPE F'	BOLSTER: NATIONAL CASTINGS PATT #44490-6	
SHANK: 43' PULLING FACE TO PIN	DT&I DWG. AAR IDENT NO. 1984	
COUPLER RELEASE RIGGING: STD. RY. COUPL. 4U-19239	BRAKE BEAM: WAB. UNIT # 570256 (INCL. PISTON)	
CUSHIONING DEVICE: KEYSTONE - 20" TRAVEL	BRAKE SHOES: RAILROAD FRICTION PRODUCTS	
	V-141 (COMPOSITION)	
		CAR : 1000
		DT & I
		MECHANICAL ENGINEERING DEPT
		6-21-65
		- REVISIONS -
		7/65 5/70

- 94 TON COIL STEEL FLAT -

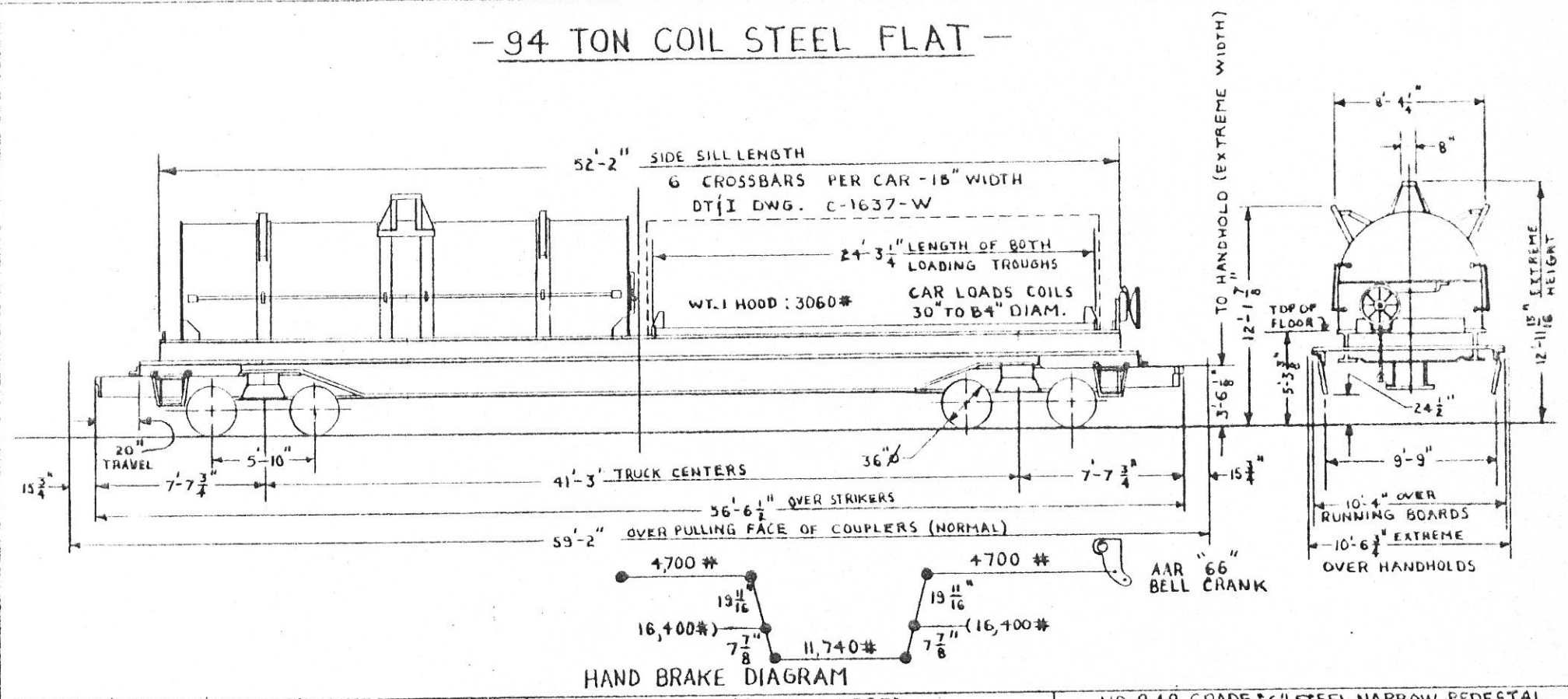

HAND BRAKE DIAGRAM

-GENERAL-		FLOOR: 3" OAK SHIPPED LAPPED		NO. 948 GRADE "C" STEEL NARROW PEDESTAL	
BUILDER: WHITEHEAD & KALES		GENERAL DWG. W. & W. R232-510-7 (DWG. V-8700)		SPRINGS: AAR D-3 14 OUTER AND 10 INNER PER TRUCK	
YEAR BUILT: 1967		HAND BRAKE: UNIVERSAL 7400-3-1966		TYPE OF TRUCK: ASF RIDE CONTROL 6 1/2" X 12"	
BUILDERS REF. RF-18025		RUNNING BOARD: U.S. GYPSUM 62280 (DWG. W-8695)		STABILIZED, EQUIPPED FOR ROLLER	
AAR CLASS: FMS		SIDE SILL: 36" WF @ 135#/FT. (MODIFIED) A-36		BEARINGS AND TRUCK MOUNTED	
NO. BUILT: 100				BRAKES: LIGHT WEIGHT, GRADE "C" STEEL	
AVE. LT. WT. 73,600 LBS.				DESIGN	
AVE. LOAD LIMIT 189,400 LBS.				WHEELS: 36" 2 WEAR WROT. STEEL H-36	
-BODY-		-TRUCK-		<p>CARS: 1100-1199</p> <p>DT. & I RAILROAD</p> <p>MECHANICAL ENGINEERING DEPT. 10-10-69</p> <p>- REVISION 6 -</p>	
AIR BRAKE MFG: WESTINGHOUSE AIR BRAKE		BOLSTER: AAR CODE B9A-111N-FX ASF PATT. NO. 22160-X (DWG. W-8702) AAR IDENT.			
AIR BRAKE SCHEDULE: ABD, WABCOPAC B3-8 1/2" UNITS		NO. 2044 GRADE "C" STEEL ROLLER BEARING			
BODY CENTER PLATE: 13 3/4" FABRICATED (DWG. Y-8800)		BOLSTER WEAR PLATE: HORIZONTAL DWG. Z-8892			
BODY SIDE BEARING: WEDGE SECTION C-1045 (DWG. Y-8130)		VERTICAL DWG. Y-8097			
CENTER SILL: SLIDING 2, 2-26 @ 41.2#/FT. A-441 STEEL		BRAKE BEAM: WEST. UNIT NO. 566247 (INCLUDE PISTON)			
CENTER SILL AREA: 24.24 SQ. IN.		BRAKE SHOES: COMPOSITION R.F.P. V-141			
COUPLER: BE-60 AHT 2 1/2" SHANK BOTT. OPER.		GENERAL DWG. ASF 73805- (DWG. W-8706)			
COUPLER RELEASE RIGGING: STANRAY 4U-2088Z-B (DWG. Y-8748)		JOURNALS: 6 1/2" X 12" ROLLER BEARINGS			
CUSHIONING DEVICE: KEYSTONE 20" TRAVEL		JOURNAL BEARINGS: TIMKEN 6 1/2" X 12" 1-A			
DRAFT GEAR: MINER RF 333		SIDE BEARINGS: STUCKI 688-B (DWG. Z-3817)			
DRAFT GEAR ATTACHMENT: GRADE "B" CAST STEEL YOKE B-Y40		SIDE FRAME: AAR CODE F9C-02 DN-UA ASF PATT. NO. 22088-A (DWG. W-8704) AAR IDENT.			
END SILL: 12" WF @ 45#/FT. 1/4" WEB PLATES					

— 95 TON COIL STEEL FLAT —

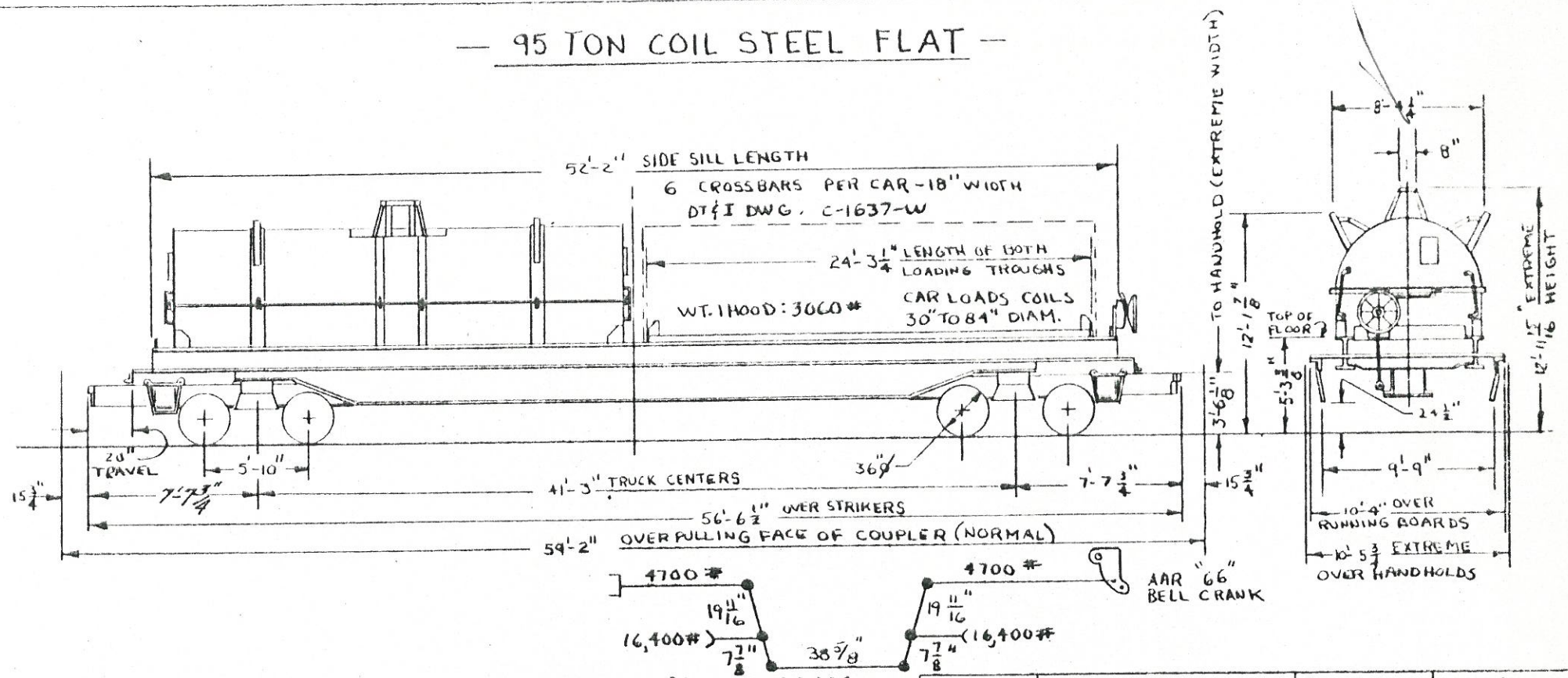

HAND BRAKE DIAGRAM LESSOR RELCO DTI LTD. LEASE 4169 TERM 11-14-83

<p align="center">— GENERAL —</p> BUILDER: WHITEHEAD AND KALES YEAR BUILT: 1968 BUILDERS REF: RF-76035 AAR CLASS: FMS NO. BUILT: 100 AVE. LT. WT.: 72,700 LBS. AVE. LOAD LIMIT: 190,300 LBS.		<p align="center">YOKE BY-40</p> END SILL: 72" WF @ 45#/FT. & 1/4" WEB PLATES FLOOR: 3" OAK SHIPPED LAPPED GENERAL DWG. W&K R232-790 (DTI DWG.) HAND BRAKE: UNIVERSAL 7400-3-1966 RUNNING BOARD: U.S. GYPSUM 62280 (DWG. W-8695) SIDE SILL: 36" WF @ 135#/FT. (MODIFIED) A-36		<p align="center">TYPE OF TRUCK ASF RIDE CONTROL 6 1/2" X 12"</p> STABILIZED, EQUIPPED FOR ROLLER BEARINGS AND TRUCK MOUNTED BRAKES. LIGHT WEIGHT, GRADE "C" STEEL DESIGN WHEELS: 36" 2 WEAR CAST STEEL CU-36	
<p align="center">— BODY —</p> AIR BRAKE MFG: WESTINGHOUSE AIR BRAKE AIR BRAKE SCHEDULE: ABD, WABCO PAC B3-8 1/2" UNITS BODY CENTER PLATE: 13 3/4" FABRICATED (DWG. Y-8800) BODY SIDE BEARING: WEDGE SECTION C-1045 (DWG. Y-8130) CENTER SILL: SLIDING Z-Z-26 @ +1.2"/FT. A-441 STEEL CENTER SILL AREA: 24.24 SQ. IN. COUPLER: BQ-60 AHT, 21 1/2" SHANK BOTT. OPER. COUPLER RELEASE RIGGING: STANHAY 4U-20882-B (DWG. V-8798) CUSHIONING DEVICE: KEYSTONE - 20" TRAVEL DRAFT GEAR: MINER RF 383 DRAFT GEAR ATTACHMENT: GRADE "B" CAST STEEL		<p align="center">— TRUCK —</p> BOLSTER: AAR CODE B9A-111N-FX ASF PATT. NO. 22160-X (DWG. W-8702) AAR IDENT. NO. 2044 GRADE "C" STEEL ROLLER BEARING BOLSTER WEAR PLATE: HORIZONTAL DWG. Z-804Z VERTICAL DWG. Y-8097 BRAKE BEAM: WEST. UNIT NO. 566247 (INCLUDE PISTON) BRAKE SHOES: COMPOSITION R.F.P. V-141 GENERAL DWG. ASF 74177 (DWG. W-8706) JOURNALS: 5 1/2" X 12" ROLLER BEARINGS JOURNAL BEARINGS: HYATT 6V 1/2" X 12" GA SIDE BEARINGS: STUCKI 688-B (DWG. Z-5817) SIDE FRAME: AAR CODE F9C-020N-UA ASF PATT. NO. 22088-A (DWG. W-8704) AAR IDENT. NO. 948 GRADE "C" STEEL NARROW PEDESTAL SPRINGS: AAR D-3 14 OUTER, 10 INNER PER TRUCK		<p align="center">CARS: 1200-1299</p> <p align="center">D.T. & I. RAILROAD</p> MECHANICAL ENGINEERING DEPT. 1-9-70 <p align="center">— REVISIONS —</p>	

- 99 TON COIL STEEL FLAT

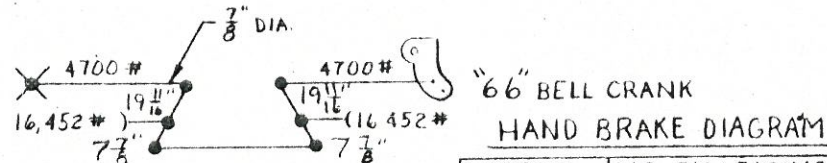
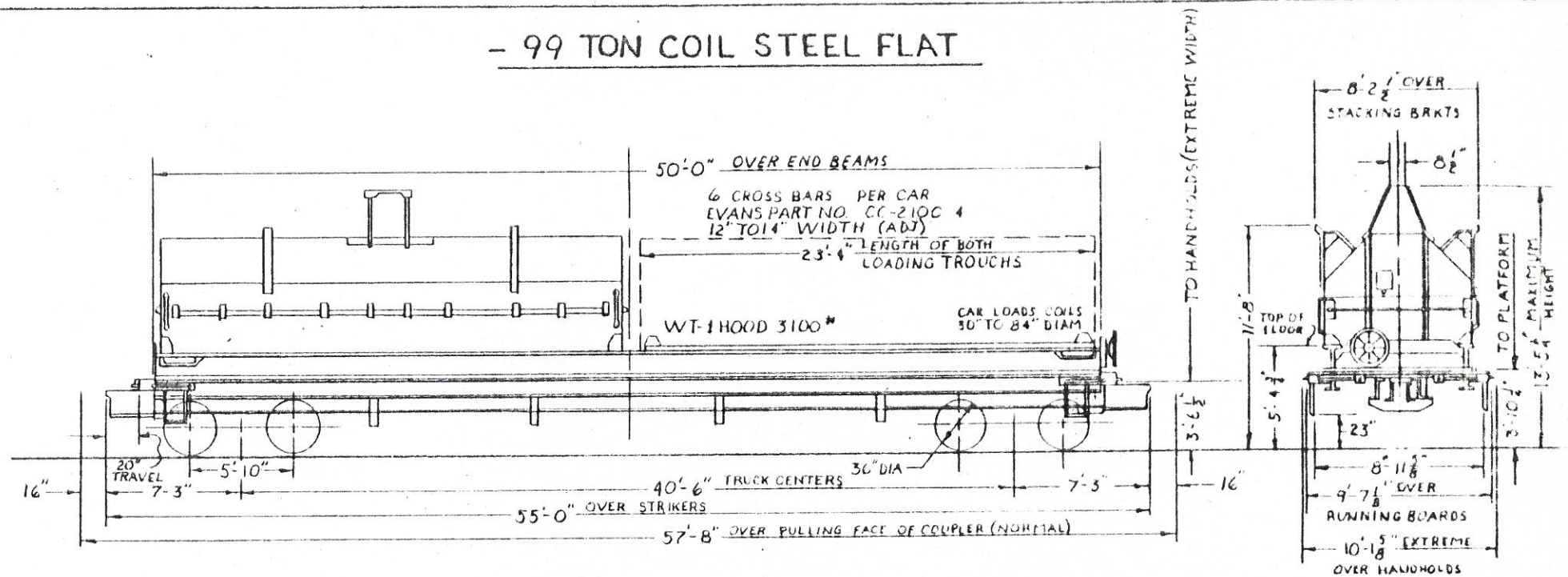

- GENERAL -		LESSOR U.S. RY LEASING CORP. LEASE 4299 TERM. 6-28-88	
BUILDER: U.S. RAILWAY EQUIPMENT CO.	DRAFT GEAR ATTACHMENT: BY-40 YOKE	APR IDENT. NO.	NARROW PEDESTAL
YEAR BUILT: 1970	END SILL: 10" WF @ 29.6#/FT. ASTM A-572-50-T2	SPRINGS: AAR D-3 14 OUTER 6 INNER COILS PER TRUCK	
BUILDERS REF: 982	FLOOR: 2 3/4" BRUCE DURA-WOOD	TYPE OF TRUCK: BARBER S-2-A	
A.A.R. CLASS: FMS	GENERAL DWG: EVANS 1E-27020-4	WHEELS: 36"-1 WEAR CAST STEEL CH-36	
AVE. LTWT.: 64200 LBS.	HAND BRAKE: AJAX #2665-B (1966)		
AVE. LOAD LIMIT: 198,800 LBS.	RUNNING BOARD: MORTON D100-003		
	SIDE SILL: FABRICATED BEAM, INLAND STEEL		
	FLANGE ASTM A-572-60-T2		
	WEB ASTM A-572-55-T2		
- BODY -		- TRUCK -	
AIR BRAKE MFG.: WESTINGHOUSE AIR BRAKE CO.	BOLSTER: A.A.R. CODE B95-08UN EN. DRESSER	CARS: 1350-1355	
AIR BRAKE SCHEDULE: ABO VALVE, WABCO PAC	PATT. NO. 80-9211 (DWR. 46-W-10082)	DT & I RAILROAD	
8-3 8 1/2" UNIT	ROLLER BEARINGS	MECHANICAL ENGINEERING DEPT. 7-22-70	
BODY CENTER PLATES: 13 3/4" CAST STEEL	BRAKE BEAM: WABCO 566297	- REVISIONS -	
"A" END WAUGH (G 3892)	BRAKE SHOES: RFP V-141 COMPOSITION		
"B" END WAUGH (G 3891)	GENERAL DWG. DRAFT W-10318		
BODY SIDE BEARING: STUCCI 794	JOURNALS: 6 1/2" 12" ROLLER BEARINGS		
CENTER SILL: SLIDING: 2- 3 26 @ 41.5#/FT. ASTM A572-50	JOURNAL BEARINGS: HYATT OR SKF		
STATIONARY: 2- 2 26 @ 31.5#/FT. ASTM A-36	SIDE BEARINGS: STUCCI 688-B (DWR. 15817)		
CENTER SILL AREA: 24.24" 1/2"	SIDE FRAME: A.A.R. CODE F95-01BN-UA, DRESSER		
STATIONARY: 18.40 1/2"	PATT. NO. B-TF-2051P (DWR. V-10083)		
COUPLER: 3 1/2" 41" (DWR. 42730) AS F.O. 12720-B			
COUPLER RELEASE RIGGING: STANBAY 4U-21080			
CUSHIONING DEVICE: HYDRO-CUSHION TYPE 13			
20" 1/2" TRAVEL CG 4046			
DRAFT GEAR: WAUGH TYPE 700 (DWR. 42730)			

99 TON COIL STEEL FLAT

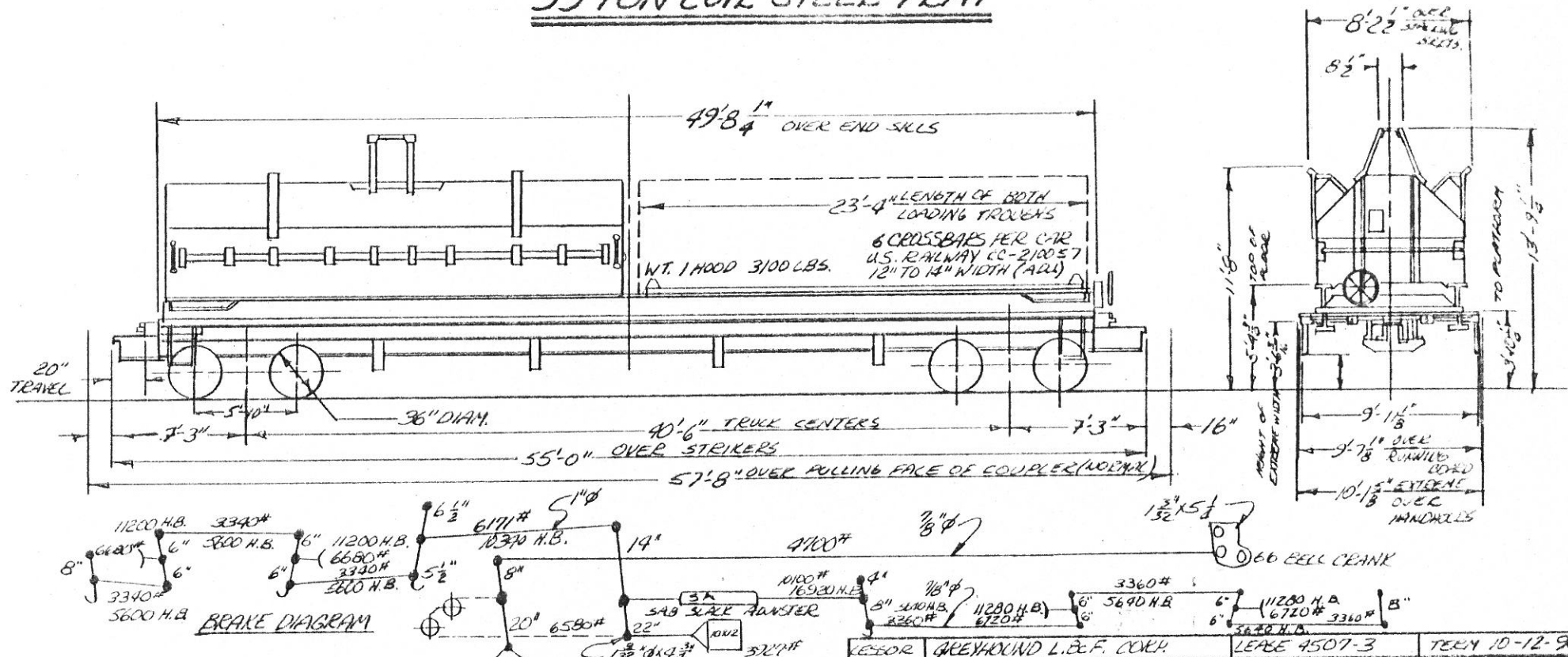

<p style="text-align: center;">-GENERAL-</p> <p>BUILDER: U.S. RAILWAY EQUIPMENT CO. (BLUE ISLAND) YEAR BUILT: 1975 BUILDER'S REFERENCE: LOT 1375 A.A.R. CLASS: FMS AVE. LT. WT: 64,500 LBS. AVE. LOAD LIMIT: 198,500 LBS.</p> <p style="text-align: center;">-BODY-</p> <p>AIR BRAKE MFG: WESTINGHOUSE AIR BRAKE CO. AIR BRAKE SCHEDULE: AARD 10" 1/2" 280 CYL. 2" H.F. BRAKE SHOES BODY CENTER RAILS: 13 1/2" CAST STEEL "A" END: DRESSER CG-4747-EH "B" END: DRESSER CG-4746-FH BODY SIDE BEARING: STUCKI DWG-791 CENTER SILL: SIDING 12" B-26 @ 412 # FT. A57M A-41 STAIRWAY: 21" B-26 @ 313 # FT. A57M A-36 CENTER SILL AREA: 41.24 IN.² STAIRWAY: 18.40 IN.² COUPLER: 6678-BIT COUPLER RELEASE ROCKET: STANRAY AU-21080-E CUSHIONING DEVICE: AMERICAN UNION TYPE 13 20" TRAVEL CG-4046-C DT&I CAR: M.H. MINER (H-501-E) RF-444 FRONT BEAR ATTACHMENT: ASE MOUNT RIG ON STEEL</p>	<p>END SILL: 10" W.F. @ 45 # FT. A.S.T.M. A-572 GR 45 T 2 FLOOR: 2 3/8" BRUE DURA WOOD GENERAL DWG: 1E-31632 (DTI V-1245B) HAND BRAKE: GILSON-NATIONAL D-1600-2-P RUNNING BOARD: MORTON D-100-003-C SIDE SILL: 2 PER CAR, FABRICATED BEAMS 2" 4 1/2" DEEP AS FOLLOWS: WEBS: 7/16" THK. A-572 GR 55 T2 STEEL TOP COVER: 10" x 1/2", BOTTOM COVER 9" x 1/2" BOTH MADE OF: A 572 GR 60 T2 STEEL</p> <p style="text-align: center;">-TRUCK-</p> <p>BOLSTER: AAR CODE B95-114N-FX DRESSER PATT. 80-9426 (DT&I DWG W-12783) AAR IDENT. NO. B-1987 14" DIAM CENTER PLATE - ROCKER BEARING BOLSTER CENTER PLATE HORIZONTAL WEAR PLATE VERTICAL WEAR PLATE BRAKE BEAM: #18 UNIT BEAM FOR COMPOSITION SHOES ORECO BRAKE SHOES: 2" HIGH FRICTION COMPOSITION (ABEX) GENERAL DWG: SCT 4017 P (DT&I Y-12496) JOURNALS: 6 1/2" x 12" ROLLER BEARING JOURNAL BEARINGS: BRENCO SIDE BEARINGS: STUCKI DOUBLE ROLLER 638-B SIDE FRAME: A.A.R. CODE F9C-02 AN-UA</p>	<p>DRESSER PATTERN NO. TE-9020-C (DT&I DWG W-12783) AAR IDENT. NO. B-882 SPRINGS: A.A.R. D-3 2 1/2" TRAVEL 14 OUTER COILS, 4 INNER COILS PER TRUCK TYPE OF TRUCK: BARBER S-2-A WHEELS: 36" I WEAR CAST STEEL</p> <p style="text-align: center;">CARS: 1375-1394</p> <p style="text-align: center;">DT&I RAILROAD MECHANICAL ENGINEERING DEPT. 9-17-78</p> <p style="text-align: center;">-REVISIONS-</p>
--	---	--

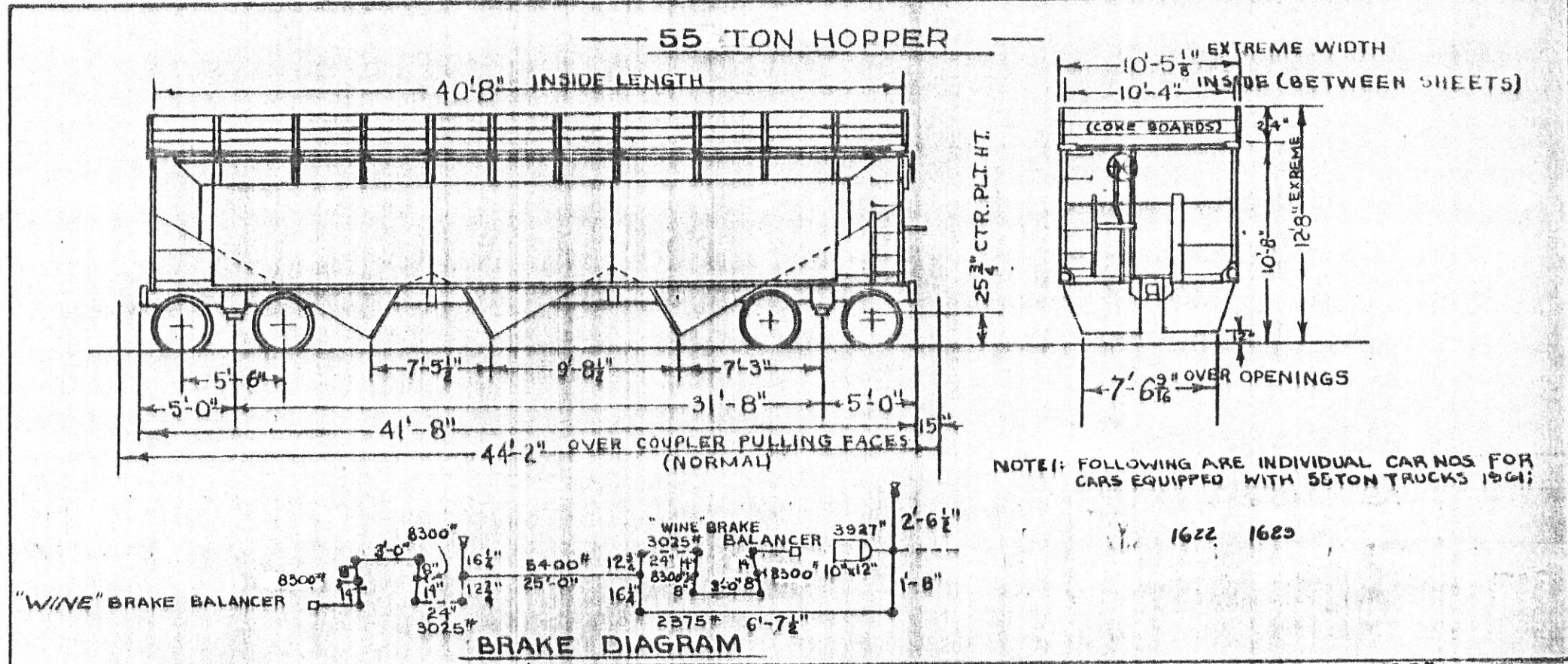

NOTE: FOLLOWING ARE INDIVIDUAL CAR NOS FOR CARS EQUIPPED WITH 55TON TRUCKS 1961:

1622 1629

— GENERAL —		DRAFT GEAR: MINER & WESTINGHOUSE	WHEELS: 1 WEAR WROT STEEL. 33" DIA.
BUILT BY: GREENVILLE STEEL CAR CO.		" " ATTACHMENT: C.S. YOKE NAT'L	WT. OF BOLSTER:
YEAR BUILT: 1948		END SILL: 6" x 3 1/2" x 5 1/8" L	" " SIDE FRAME:
BUILDERS REF: 1506		FLOORING: 1/4" PLT.	" " ONE TRUCK:
RR. SPEC. NO.: 123		GEN. DRAWING: 20842-A D.T. & I. - V-1231	
AAR CLASS: HTC		HAND BRAKE: "AJAX"	
NO. BUILT: 37 (CONVERTED FROM 11 TON)		SIDE SILL: 15" x 3 1/2" x 1 1/8" L	
CAPY.: 27730 C.U.F.T. WITH COKE BOARDS 3552 CU.F.T.		" " BRG. CENTERS: 4'-2"	
AVERAGE LT. WT.: 46000 LBS			NOTE: CARS MARKED * HAVE COKE BOARDS REMOVED, ACCOUNT LURMET SCRAP LOADING
" " LOAD LIMIT: 150,100 LBS			
— BODY —		— TRUCK —	
AIRBRAKE MFR - N.Y.A.B		BOLSTER: BSC PAT. B-5321 WITH DL. FULCRUM EXT.	
" " SCHEDULE 1 A.B.		BRAKE BEAMS: UNIT TYPE - NO 18	
BODY CTR PLT: 13 1/4" FORGED STEEL		CENTER PLATE: INTEGRAL	
" " SIDE BRG: HARDENED STEEL PLT.		GEN. DRAWING: DT. & I. W-3438	
CENTER SILL: 12 1/2" x 3 1/2"		JOURNAL: 5 1/2" x 10" BOX: INTEGRAL	
" " COVER PLATE: NONE		SIDE BRG: "STUCKI" ROLLER TYPE	
" " AREA: 21.3 SQ. IN.		" " FRAME: AAR IDENT NO. 289	
COUPLER: "E" 6 1/2" x 8" - SLOTTED BOTTOM OP		SPRINGS: 3 1/8" TRAVEL - ASF	
" " RELEASE FIG: "IMPERIAL" ROTARY			
DOOR FIXTURES: WINE		TYPE OF TRUCK: UNIT A-3 RIDE CONTROL	
		SPRING PLANKLESS	
			CARS: 1600-1649
			D.T. & I.
			MOTIVE POWER DEPT. 5-23-62
			REVISION
			7/63 1/65 7/70 1/72 8/78

- 99 TON COIL STEEL FLAT -

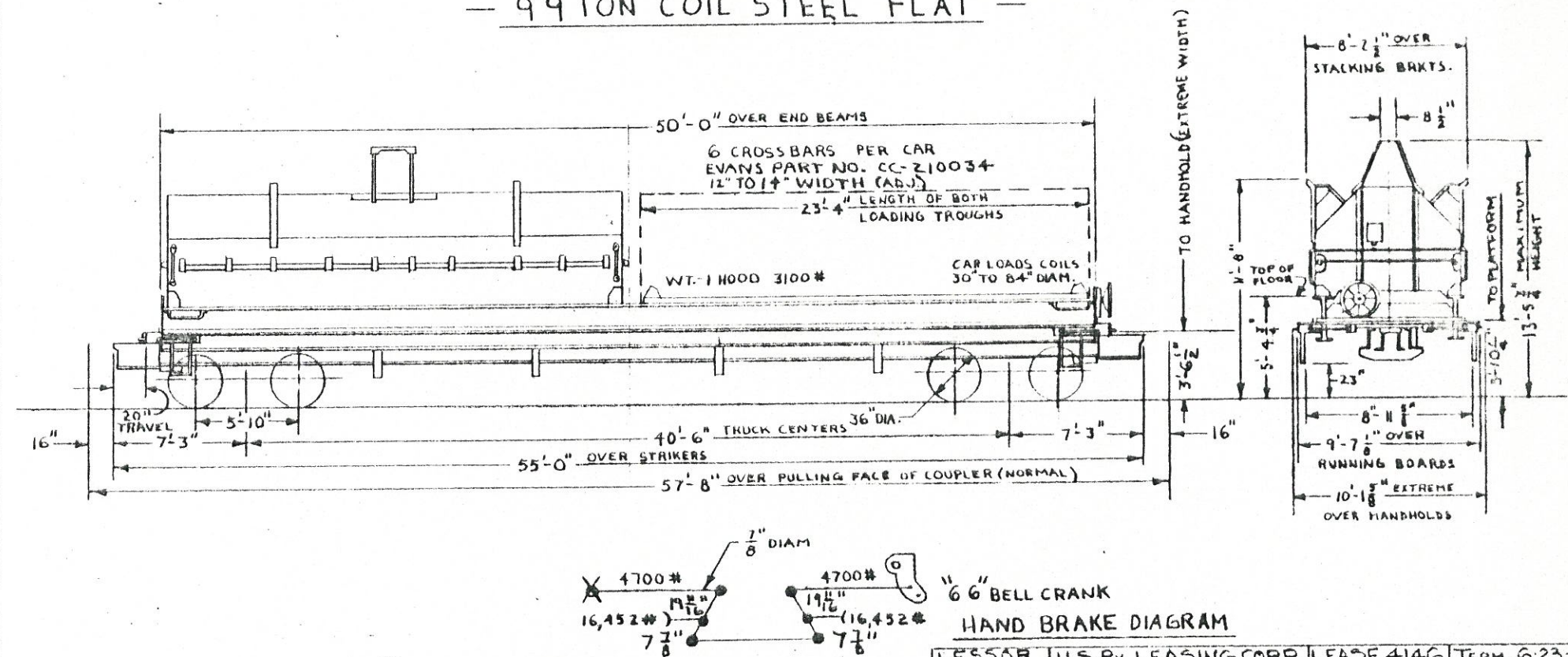

LESSOR | U.S. RY LEASING CORP. LEASE 4146 | TERM. 6-23-83

<p align="center">- GENERAL -</p> <p>BUILDER: EVANS PRODUCTS CO. YEAR BUILT: 1968 BUILDERS REF.: 1-6019 A.A.R. CLASS: FM5 AVE. LT. WT.: 63100 LBS. AVE. LOAD LIMIT: 199,900 LBS.</p>		<p>DRAFT GEAR ATTACHMENT: GRADE "B" C.S. 13-Y40 YOKE END SILL: 10" WF @ 29#/FT. A-572-50-T2 FLOOR: 2 3/8" BRUCE "DURAWOOD" GENERAL DWG.: EVANS PRODUCTS 1E-27020-G HAND BRAKE: AJAX 14665-B (1966) RUNNING BOARD MORTON MFG. CO. DWG. D100-003 SIDE SILL: FABRICATED WEB A-572-55-T2 STEEL FLANGE A-572-60-T2 STEEL</p>	<p>SPRINGS: AAR D-3 14 OUTER, 8 INNER COILS PER TRUCK TYPE OF TRUCK: BARBER S-2-A 6 1/2" X 12" STABILIZED, EQUIPPED FOR UNIT BRAKE BEAMS. WHEELS: 36" 1 WEAR CAST STEEL CH-36</p>
<p align="center">- BODY -</p> <p>AIR BRAKE MFG.: WESTINGHOUSE AIR BRAKE AIR BRAKE SCHEDULE: ABD, WABCO PAC B-3 8 1/2" UNITS BODY CENTER PLATES: 13 3/4" CAST STEEL "A" END WAUGH CG-3881 "B" END WAUGH CG-3882 BODY SIDE BEARING: STUCKI 744 CENTER SILL: SLIDING: 2, 2-26 @ 41.2#/FT. A-572-50-T2 STATIONARY: 2, 2-26 @ 31.3#/FT. A-36 CENTER SILL AREA: SLIDING: 24.24 SQ. IN. STATIONARY: 18.40 SQ. IN. COUPLER: BE-67-HT 25" CHANK BOTT. OPER. COUPLER RELEASE RIGGING: STANRAY 4-U-21080 CUSHIONING DEVICE: "HYDRA-CUSHION" TYPE 13 20" TRAVEL CG-4046 DRAFT GEAR: WAUGH 700 (M-901)</p>		<p align="center">- TRUCK -</p> <p>BOLSTER: AAR CODE: B9S-ORUN-BN SYM. WAYNE PAT. NO. 80-9211 (OFF. W. 10082) AAR IDENT. NO. B-2064 ROLLER BEARING BRAKE BEAM: WESTINGHOUSE 566247 (INCLUDING PISTON) BRAKE SHOES: REF. V-141 GENERAL DWG.: EVANS PRODUCTS 1X-26941-B JOURNALS: 6 1/2" X 12" ROLLER BEARINGS JOURNAL BEARINGS: TIMKEN 6 1/2" X 12" 1-A SIDE BEARINGS: STUCKI 688-B (DWG. #5817) SIDE FRAME: AAR CODE: F9S-OIPN-UA SYM. WAYNE PAT. NO. TF-9057 (OFF. W. 10083) AAR IDENT. NO.</p>	<p align="center">CARS: 1300 - 1349 D.T. I RAILROAD MECHANICAL ENGINEERING DEPT. 12-3-69 - REVISIONS -</p>

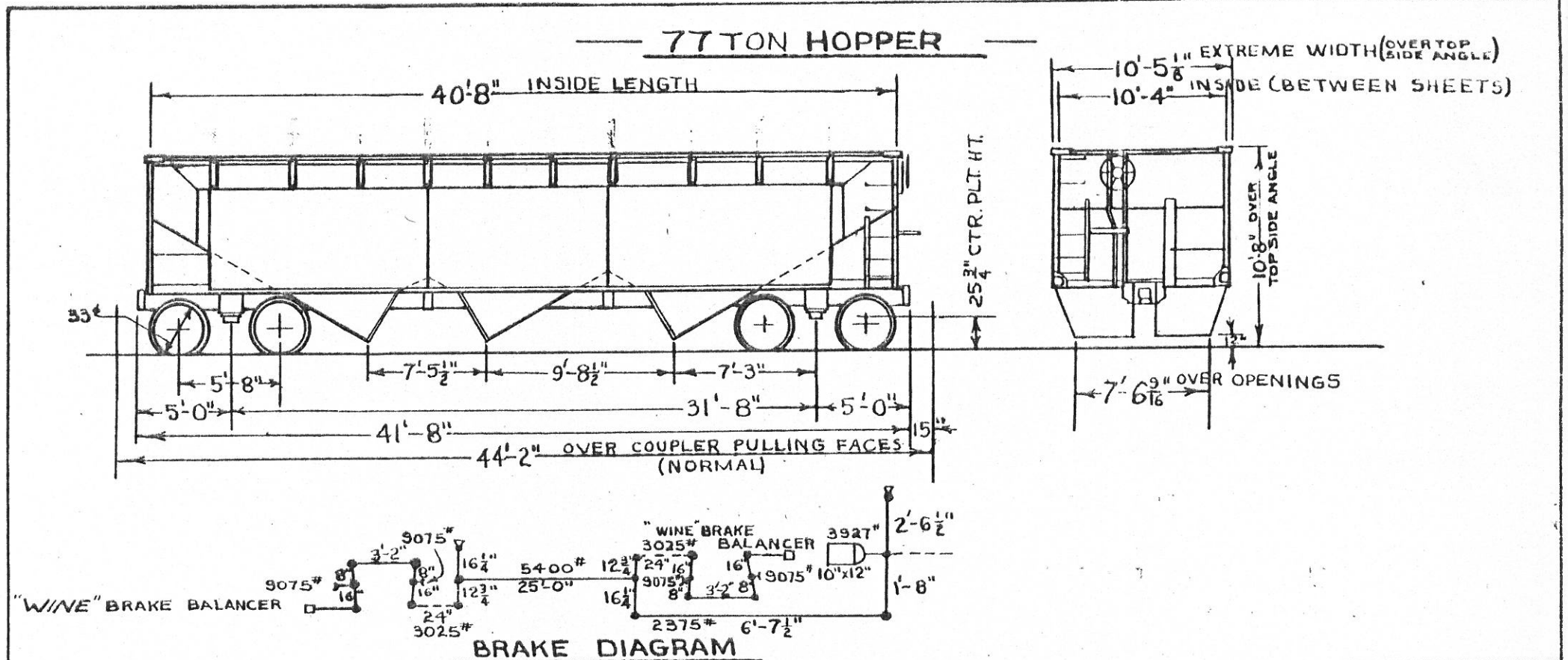

— GENERAL —		— TRUCK —	
BUILT BY: GREENVILLE STEEL CAR CO.	DRAFT GEAR: MINER & WESTINGHOUSE	WHEELS: 1 WEAR WROT STEEL (25 3/8 WERE CAST IRON)	
YEAR BUILT: 1948	" " ATTACHMENT: C.S. YOKE NAT'L	WT. OF BOLSTER:	
BUILDERS REF.: 506	END SILL: 6" x 3 1/2" x 5/16" L	" " SIDE FRAME:	
RR. SPEC. NO.: 123	FLOORING: 1/4" PLT.	" " ONE TRUCK: 8400 LBS.	
AAR CLASS: HT	GEN. DRAWING: 20842-A D.T. & I.-V-1231		
NO. BUILT: 50	HAND BRAKE: "AJAX"		
CAPY.: 2773 CU. FT.; WITH COKE BOARDS: 9552 CU. FT.	SIDE SILL: 5" x 3 1/2" x 3/8" L		
AVERAGE LT. WT.: 48,900 LBS.	" " BRG. CENTERS: 4'-2"		
" " LOAD LIMIT: 171,100 LBS.			
— BODY —		CARS: 1600-1649	
AIRBRAKE MFR.: N.Y.A.B.	BOLSTER: D-5834A D.T. & I.-W-2466	D.T. & I.	
" " SCHEDULE: AB	BRAKE BEAMS: UNIT TYPE - NO. 15	MOTIVE POWER DEPT. 4-8-48	
BODY CTR. PLT.: 1334" FORGED STEEL	" " SAFETY: "CRECO"	REVISION	
" " SIDE BRG.: HARDENED STEEL PLT.	CENTER PLATE: INTEGRAL	1/56 3/57 5/57 7/60 5/162 7/163 1/65 7/70	
CENTER SILL: 12 7/8" x 36.2"	GEN. DRAWING: DT: & I. V-1231	FAM FAH	
" " COVER PLATE: NONE	JOURNAL: 6" x 11" BOX: INTEGRAL		
" " AREA: 21.9 SQ. IN.	RR. SPEC. NO. 117		
COUPLER: "E" 6 1/2" x 8" - SLOTTED BOTTOM OR	SIDE BRG.: "STUCKI"		
" " RELEASE RIG: "IMPERIAL" ROTARY	" " FRAME: F-769 D.T. & I.-W-2817		
DOOR FIXTURES: WINE	SPRINGS: UNION SPRING & MFR CO.		
	(COIL-ELLIPTIC - SYM-GOULD R-5035-A)		
	TYPE OF TRUCK: UNIT SPRING PLANKLESS		

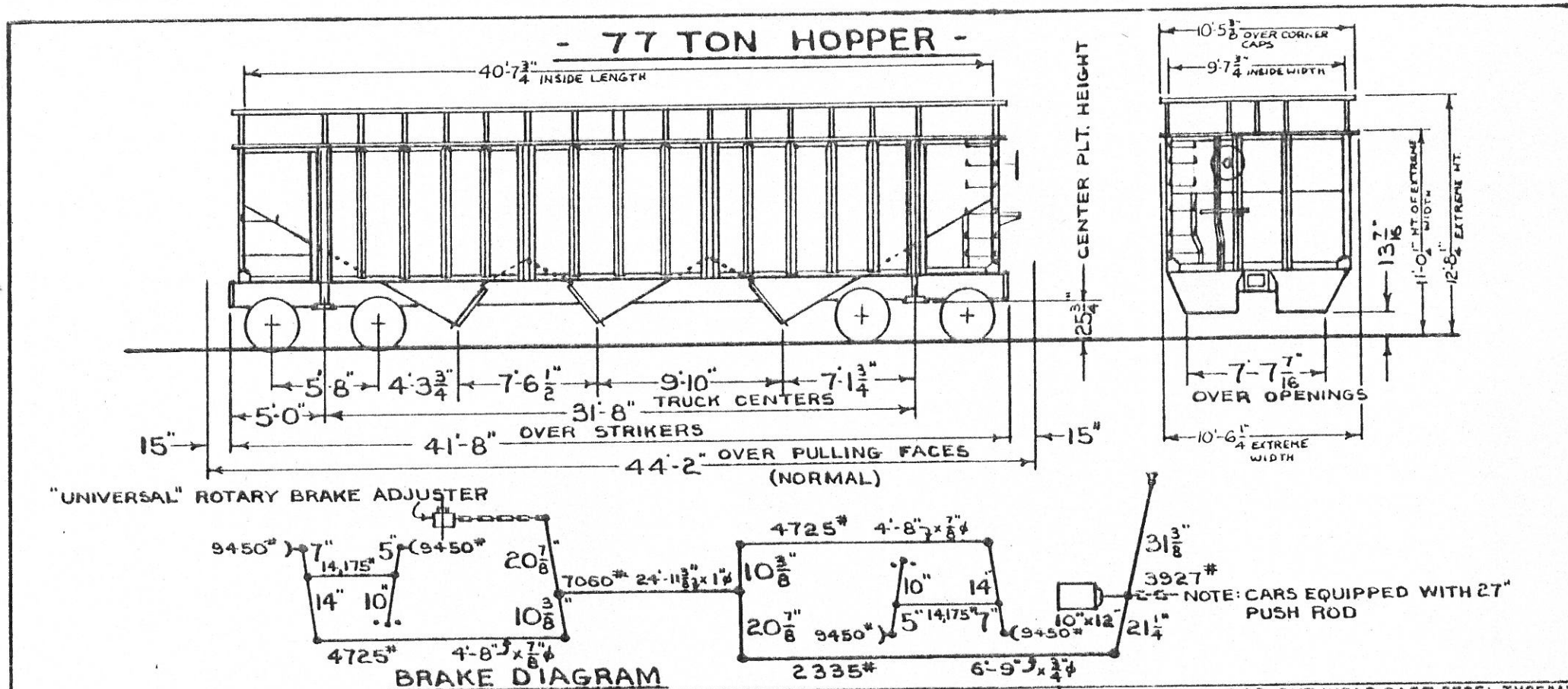

- GENERAL -		DRAFT GEAR: 1900-1999 CARDWELL-WEST, NY-II-F		WHEELS: 1800-1849 ONE WEAR CAST STEEL TYPE "A"	
BUILT BY: GREENVILLE STEEL CAR CO.		DRAFT GEAR ATTACHMENTS: C.S. YOKE, Y-40(S.G.)		1850-1999 ONE WEAR WROUGHT STEEL	
YEAR BUILT: 1959		END SILL: 6"x 3 1/2" x 3/8" ANGLE		WEIGHT OF ONE BOLSTER:	
BUILDERS REF: O.O.-729		FLOOR: 5/16" C.B.S. PLT.		WEIGHT OF ONE SIDE FRAME:	
AAR CLASS: HTC		GENERAL DWG: G.S.C. 25557-B, DT&I V-4680		WEIGHT OF ONE TRUCK: 8250 LBS.	
NO. BUILT: 200		HAND BRAKE: VERTICAL WHEEL		SPRINGS: AAR "D-3", 2 1/2" TRAVEL 14 OUTER, 2 INNER	
CAPY.: 3340 CU. FT.		1800-1899 - MINER D-3290-XL		COILS PER TRUCK	
AVE. LT. WT.: 52,200 LBS.		1900-1999 - AJAX 14377-J			
AVE. LOAD LIMIT: 169,800 LBS.		SIDE SILL: 5"x 3 1/2" x 3/8" ANGLE			
		SIDE BEARING CENTERS: 4'-2"			
		TOP SIDE ANGLE: 5"x 3 1/2" x 3/8" AT 13.0°/FT. B.A.			
		OR FABRICATED OF 5"x 3 1/2" x 3/8" AND 3"x 3" x 3/8" ANGLES			
- BODY -		- TRUCK -		CARS: 1800-1999	
AIR BRAKE MFG: SECOND HAND		BOLSTER: AAR CODE B7A-D168-BN BUCKEYE PAT.		D.T.&I.	
AIR BRAKE SCHEDULE: AB 1012		B-7084 (D.T.&I. W-4659) AAR INDENT. NO. 1295			
BODY CENTER PLATE: 13 3/4" FORGED STEEL		BRAKE BEAM: NO. 18 UNIT, CRECO & BUFFALO			
BODY SIDE BEARING: 4"x 3/8" PLT. AAR SPEC. M-126/C		CENTER PLATE: INTEGRAL			
CENTER SILL: 2, Z-26 AT 51.2°/FT. ROLLED SECTIONS		GENERAL DWG: ASF T1805- DWG W-4681			
CENTER SILL AREA: 30.12 SQ. IN.		JOURNAL: 6" II" INTEGRAL BOX			
COUPLER: TYPE "E" 6 1/4" x 8" SLOTTED, BOTTOM OPA.		SIDE BEARINGS: STUCKI 686-C			
COUPLER RELEASE RIG. STD. RY. EQUIP. IU-12520		SIDE FRAME: AAR CODE: F7A-D168-UA ASF		MOTIVE POWER DEPT 3-11-59	
DOORS: GREENVILLE		PART: 2108F DWG W-4656 AAR INDENT. NO. 616		- REVISIONS -	
DOOR FIXTURES: WINE RY. APPLIANCE		TYPE OF TRUCK: TON A-3 RIDE CONTROL			
DRAFT GEAR: 1800-1899 - MINER A-22-XL		SPRING PLANKLESS, EQUIP. FOR UNIT BRAKE BEAM			
				1/65 2/70 3/79	

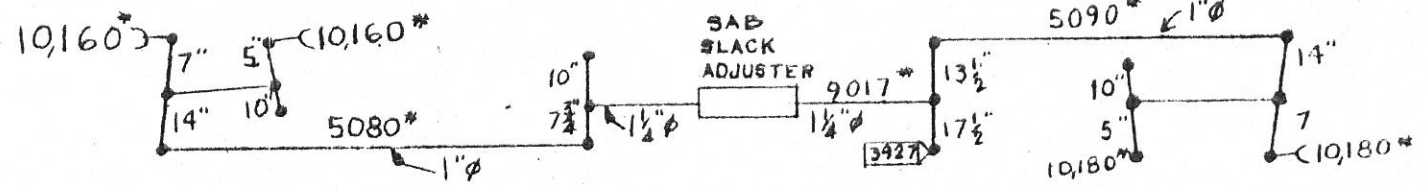
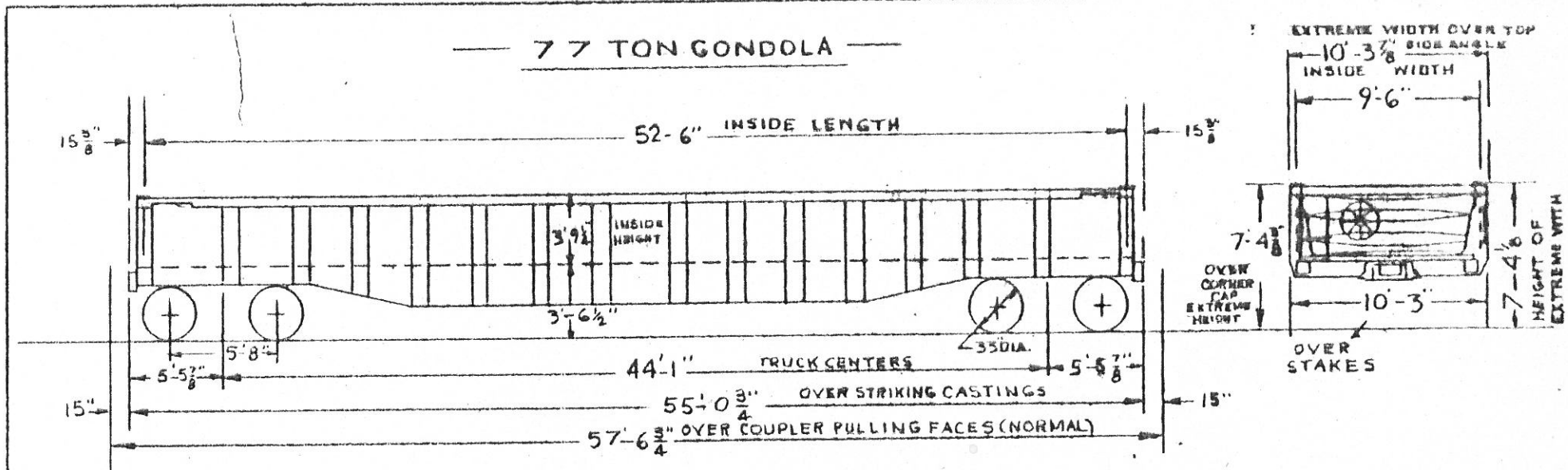

BRAKE DIAGRAM

- GENERAL -		LESSOR	U.S. LEASING INTER.	LEASE 4172	TERM 12-31-80
BUILDER - GREENVILLE STEEL CAR CO.		DRAFT GEAR: MINER A-22-XB		SIDE FRAME: AAR CODE F75-02BN-UA BUCKEYE	
YEAR BUILT: 1944 REWORKED 1968		ATTACHMENT: C5, YOKE B.S.C.		PATT. NO. F-7161 D.T.F.I. DWG. V-7876 AAR	
BUILDERS REF: 00-414		ENDS: STANRAY 5E-3771-C (DWG. W-5486)		IDENT. NO. B-866 NARROW PEDESTAL	
R.R. CO. SPEC. NO. -110		END SILL: 12 @ 20.7 LBS. E		SPRINGS: 8-310 OUTER-18 INNER COILS PER TRUCK	
A.A.R. CLASS: GB		FLOORING: 3/4" STEEL PLATE		TYPE OF TRUCK: 6'X11" BARBER S-2-A STABILIZED	
NO. BUILT: 100 NO. REWORKED 95		GENERAL DWG: 19179 D.T.F.I. V-2448		NARROW PEDESTAL ROLLER BEARING	
CAPY: 1880 CU. FT.		HAND BRAKE: EQUIPCO 3760-E 1942		WHEELS: 32" ONE WEARCAST STEEL - CJ-33	
AVERAGE LT. WT.: 65,700		SIDE SILL: FISH BELLY			
LOAD LIMIT: 184,300		SIDE BRG CENTERS: 4'-2"			
		TOP SIDE ANGLE: 5" X 1/2" X 3/8" BULB ANGLE			
		TOP SIDE ANGLE REINFORCEMENT: 5" X 5" X 3/8" ANGLE			
- BODY -		- TRUCK -		CARS: 2000-2094	
AIR BRAKE MFR: NY A.B. CO.		BOLSTER: AAR CODE 473-0CE B-BN BUCKEYE PATT.		D.T. & I. RAILROAD	
" SCHEDULE: ABD-10		NO. B-7291 D.T.F.I. DWG. W-9032 AAR IDENT		MECHANICAL ENGINEERING DEPT. 11-25-69	
BODY CENTER PLT.: 13 1/2" FORGED STEEL		NO. B-1245 ROLLER BEARING		REVISION	
" SIDE BRG: 1/2" HARDENED STEEL PLT.		BRAKE BEAM: 2008-2016			
CENTER SILL: C.B. 2-26 36.2 LBS./FT.		2017-2094			
CENTER SILL AREA: 41.70 SQ. IN.		GENERAL DWG: D.T.F.I. DWG. Y-9053			
COUPLER: "E" 6 1/2" X "B" SLOTTED BOTTOM		JOURNALS: 2" X 11"			
COUPLER RELEASE RIG: IMPERIAL ROTARY		JOURNAL BEARINGS: HYATT 2" X 11"			
STANRAY-1U-1557-B (D.T. & I. DWG. Y-5494)		SIDE BEARINGS: SINGLE ROLLER TYPE STOKI 456-G			
		(D.T.F.I. DWG. Y-1470)			
				8/78	

90 TON GONDOLA

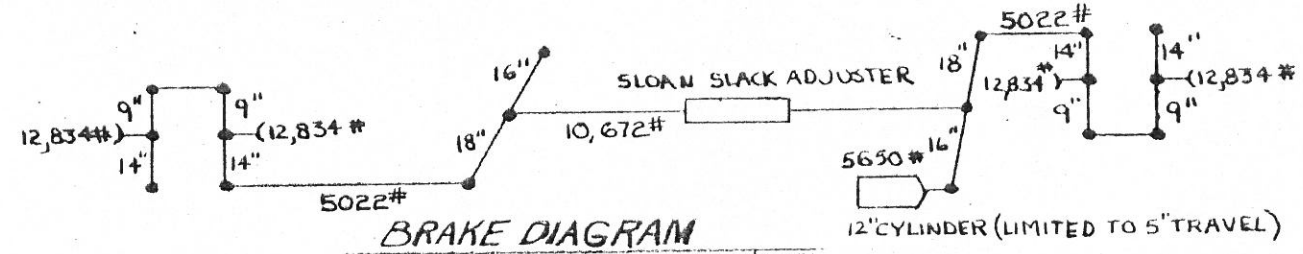
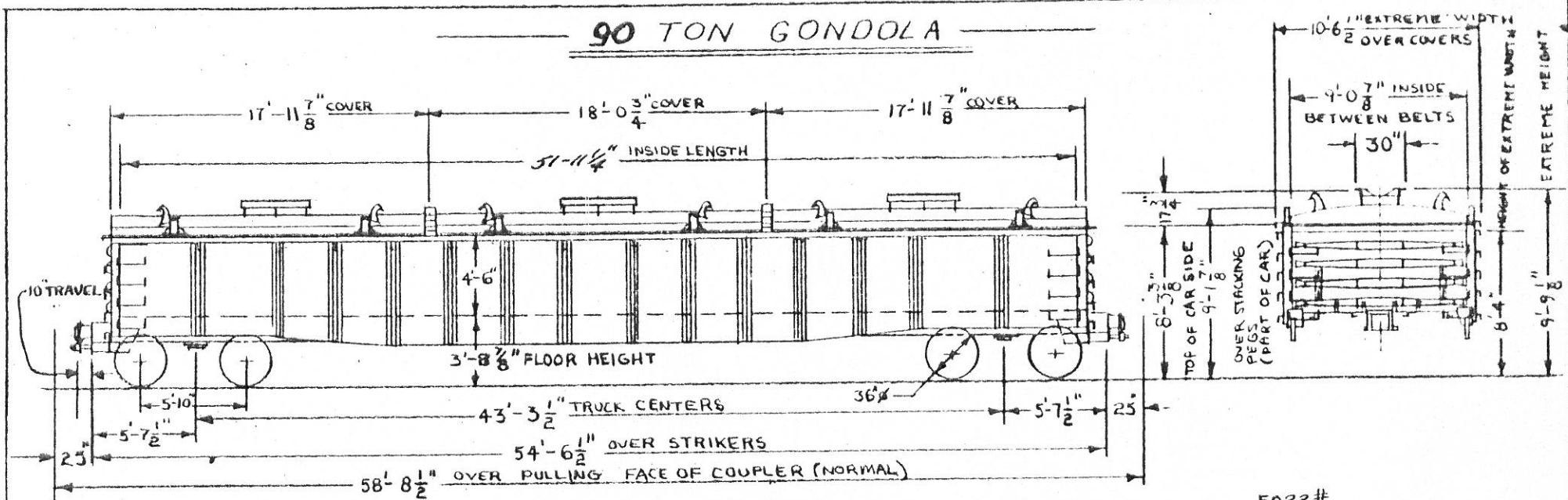

CARS EQUIPPED AS SHOWN,
9500, 9502, 9508
ROOF REMOVED FROM 9501.

	LESSOR	NAT'L. EQUIP. LEASING
GENERAL	9" TRAVEL IN BUFF, 1" TRAVEL IN DRAFT	LEASE 4/3/3 TERM 9-14-84
BUILDER: GREENVILLE STEEL CAR	ENDS: STANRAY 3E-22288-A (DWG. W-9629) A-572-50	JOURNAL BEARINGS: TIMKEN 6 1/2" X 12" 1-A
YEAR BUILT: 1969	END BILL: 6" X 3 1/2" X 3/8" ANGLE	SIDE BEARINGS: STUCKI 688-B (DWG. 25817)
BUILDERS REF.: O.O. 989	FLOOR: REPUBLIC-COMPOSITE-2 3/8" Y.P. WOOD (TREATED)	SIDE FRAMES: AAR CODE F9C-038M-UA ASF
AAR CLASS: GBSR	GENERAL ARRANGEMENT: GSC 33994-A	PAT. NO. 22052-AJ (DWG. W-9462)
NO. BUILT: 10	HAND BRAKE: AJAX 14665-B 1966	AAR IDENT. NO. 920 NARROW PEDESTAL
CAPY.: 2228 CU. FT.	ROOF: SHUNK LL-5003 (REMOVABLE) 3 PIECE, V-10891	SIDE FRAME WEAR PLATES: BOLT ON TYPE (DWG. 2-9455)
AVE. LT. WT.: 88,000 LBS.	SIDESILL: 6" X 4" X 3/8" ANGLE A-572-50	SPRINGS: AAR D-3 14 OUTER, 10 INNER COILS PER TRUCK
AVE. LOAD LIMIT: 181,000 LBS.	SIDE BEARING CENTERS: 4'-2"	TYPE OF TRUCK: ASF RIDE CONTROL 6 1/2" X 12" STABILIZED, NARROW PEDESTAL ROLLER BEARING
BODY	SLACK ADJUSTER: SLOAN	WHEELS: 36" / WEAR WROUGHT STEEL H-36
AIR BRAKE MFG.: NEW YORK AIR BRAKE CO.	TOP END ANGLE:	
AIR BRAKE SCHEDULE: ABD WITH 12 X 10 CYLINDER	TOP SIDE ANGLE 1 5" X 4 1/2" X 7/16" BULL ANGLE A-36 WITH 5" X 5" X 1/2" ANGLE REINFORCEMENT	
BODY CENTER PLATE: 13 3/4"	TRUCK	CARS: 9500-9509
BULKHEADS: JEVANS PRODUCTS (4 PER CAR) 03-208301	BOLSTER: AAR CODE 09A-1285-FH ASF PAT. NO. 22256-BR (DWG. W-9461) AAR IDENT. NO. 2117 ROLLER BEARING	D.T. & I.
CENTER SILL: 2, 2-26 @ 41.2"	BOLSTER WEAR PLATE: HORIZONTAL- VERTICAL - DWG. 2-9454	MECHANICAL ENGINEERING DEPT 11-25-69
CENTER SILL AREA: 24.24 SQ. IN.	BRAKE BEAM: #24 UNIT TYPE	REVISION
COUPLER: B-EG0A-HT 2 1/2" SHANK BOT. OPER.	GENERAL DWG.: ASF 74441 - D.T.I. W-9460	
COUPLER RELEASE RIGGING: STANRAY 10-22275-A (DWG. X-9(30))	JOURNALS: 6 1/2" X 12" ROLLER BEARING	
CROSS OVER STEP: ADEX 4530-A		
CUSHIONING: 1 HEIGHTMASTER END OF CAR		

90 TON GONDOLA

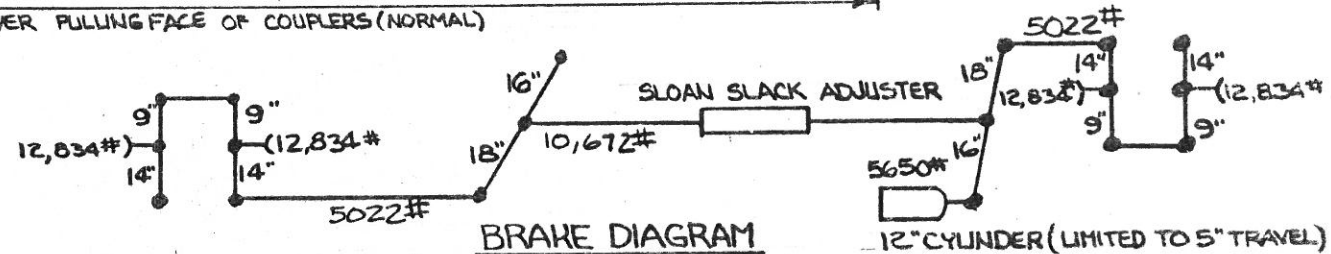
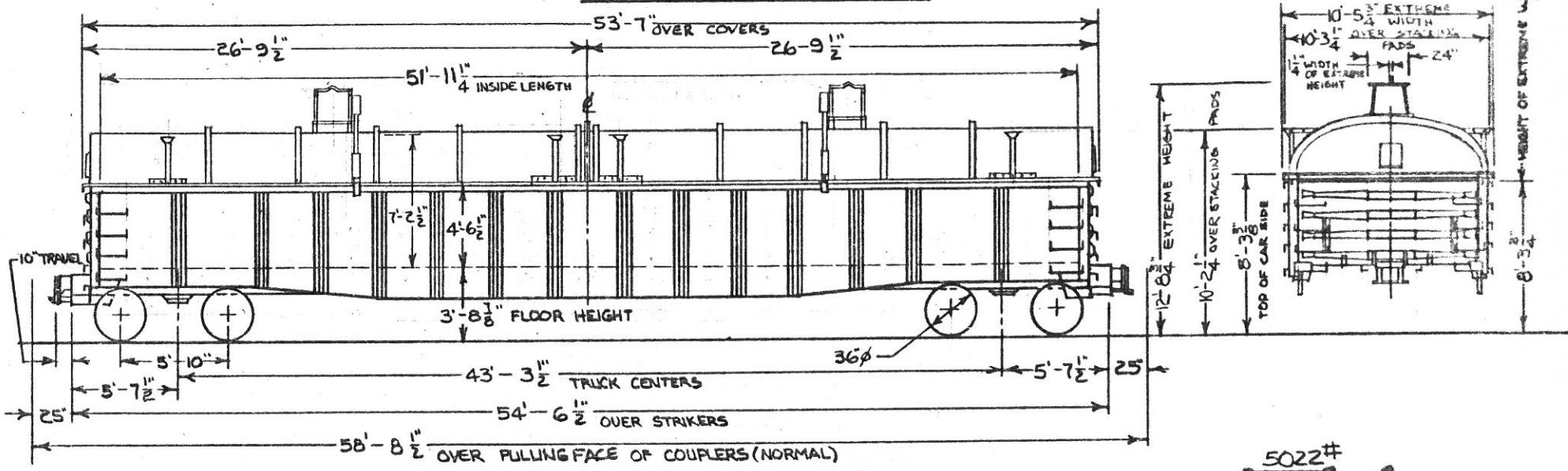

CAR EQUIPPED AS SHOWN FOR WIRE LOADING
 9503, 9504, 9505,
 9506, 9507, 9509

	LESSOR	NAT'L EQUIP. LEASING	LEASE 4213	TERM 9-14-84
- GENERAL -	ENDS: STANRAY 3E-22288-A (DWG. W-9629) A-572-50	JOURNAL BEARINGS: TIMKEN 6 1/2" x 12" 1-A		
BUILDER: GREENVILLE STEEL CAR CO.	END SILL: 6" x 3 1/2" x 3/8" ANGLE	SIDE BEARINGS: STUCKI 688-B (DWG. Z-5817)		
YEAR BUILT: 1969	FLOOR: REPUBLIC-COMPOSITE-2 3/8" P.WOOD (TREATED)	SIDE FRAMES: A.A.R. CODE F9C-03BN-UA ASF PAT. NO. 22052-AJ (DWG. W-9462)		
BUILDERS REF.: O.O. 989	GENERAL ARRANGEMENT: GSC-33994-A (DWG. V-12901)	A.A.R. IDENT. NO. 920 NARROW PEDESTAL		
A.A.R. CLASS: 8BSR	HAND BRAKE: AJAX 14665-B 1966	SIDE FRAME WEAR PLATES: BOLT ON TYPE (DWG. Z-9455)		
NO BUILT: 10	ROOF: BOMBARDIER-FIBERGLASS (REMOVABLE)	SPRINGS: AAR D-3 14 OUTER, 10 INNER COILS PER TRUCK		
CAPY: 2228 CU. FT.	SIDE SILL: 6" x 4" x 3/8" ANGLE A-572-50	TYPE OF TRUCK: ASF RIDE CONTROL 6 1/2" x 12" STABILIZED, NARROW PEDESTAL ROLLER BEARING		
AVE. LT. WT.: LBS.	SIDE BEARING CENTERS: 4'-2"	WHEELS: 36" 1 WEAR WROUGHT STEEL H-36		
AVE LOAD LIMIT: LBS.	SLACK ADJUSTOR: SLOAN			
	TOP END ANGLE: 5" x 4 1/2" x 1/16" BULB ANGLE A-572-50			
- BODY -	TOP SIDE ANGLE: 5" x 4 1/2" x 1/16" BULB ANGLE A-36 WITH 5" x 5" x 1/2" ANGLE REINFORCEMENT			
AIR BRAKE MFG.: NEW YORK AIR BRAKE CO.				
AIR BRAKE SCHEDULE: ABD WITH 12" x 10" CYLINDER				
BODY CENTER PLATE: 13 3/8"				
BODY SIDE BEARING:				
CENTER SILL: 2, Z-26 @ 41.24/FT. A-572-50				
CENTER SILL AREA: 24.24 SQ. IN.				
COUPLER: B-EGCA-HT 2 1/8" SHANK BOT. OPER.				
COUPLER RELEASE RIGGINGS: STANRAY 1U-22293-A (DWG. X-9630)				
CROSS OVER STEP: APEX 4530-A				
CUSHIONING: FREIGHT MASTER END OF CAR 9" TRAVEL IN BUFF, 1" TRAVEL IN DRAFT				
	- TRUCK -			
	BOLSTER: AAR CODE B9A-12BS-FN ASF PAT. NO. 2225-6788 (DWG. W-9461) AAR IDENT. NO. 2117 ROLLER BEARING.			
	BOLSTER WEAR PLATE: HORIZONTAL- VERTICAL - DWG Z-9454			
	BRAKE BEAM: #24 UNIT TYPE			
	GENERAL DWG.: ASF 74441 -- DT&CI W-9460			
	JOURNALS: 6 1/2" x 12" ROLLER BEARING.			
		CARS: 9500-9509		
		D. T. & I		
		MECHANICAL ENGINEERING DEPT.		9-7-79
		-- REVISION --		

88 TON GONDOLA

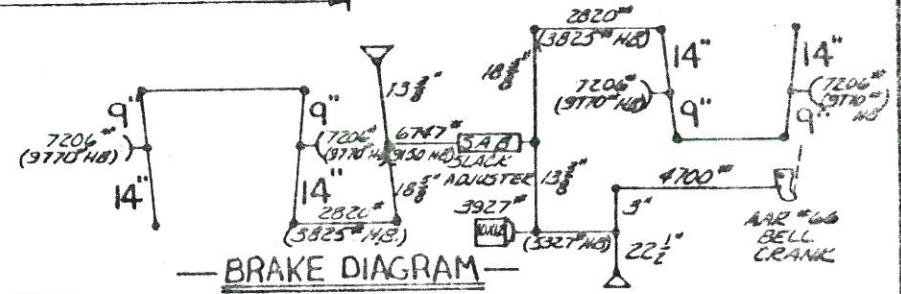
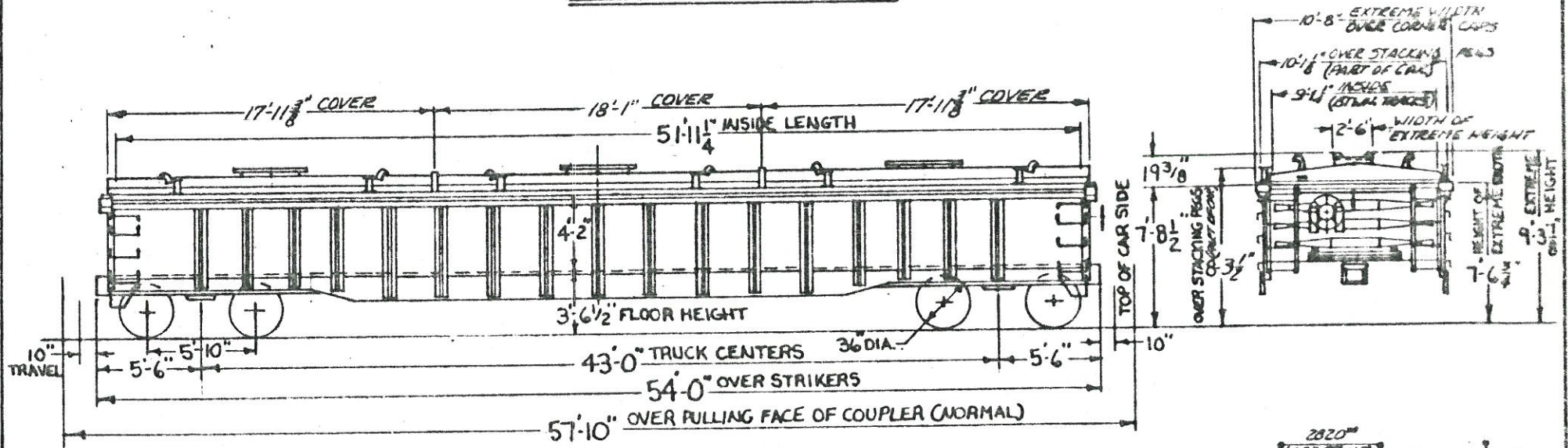

NOTE: ROOF & BULKHEAD REMOVED FROM: 9520, 9522, 9526, 9528, 9532, 9533, 9535, 9536, 9538, 9541, 9545

- GENERAL -	10" TRAVEL IN BUFF; 7" TRAVEL IN DRAFT (QT#1 DWG. V-11085)	SIDE FRAMES: AAR CODE: NONE B5C. PAT. NO. F-10021 (DWG. V-10949) AAR. IDENT. NO. B-5046
BUILDER: GREENVILLE STEEL CAR	ENDS: STANRAY 3E-23685-A 1/2" A-44 (DT#1 DWG. W-0768)	NARROW PEDESTAL
YEAR BUILT: 1972	END SILL: G" X 4" X 5/8" ANGLE ASTM A441	
BUILDER'S REF.: O.O. 1055	FLOOR: PLATE 3/8" STEEL ASTM A-36 (20% COMP)	
AAR CLASS: G85R	GENERAL ARRGT.: GSC 35680 - DT&I DWG. V-11064	
NO. BUILT: 30	HANDBRAKE: MINER 24083-F 1/2" G" DT&I DWG. X-10934	SPRINGS: CRUCIBLE STEEL AAR D-3, 14 OUTER AND 8 INNER COILS PER TRUCK
CAPV.: 1973 CU. FT.	ROOF: SHUNK II-5006 (REMOVABLE) 3 PC. DT&I DWG. Y-10891	TYPE OF TRUCK: BARBERS 2-A 6 1/2" X 12" STABILIZED
AVE. LT. WT.: 85500 LBS.	SIDE SILL: 18" @ 42.7" FT. CHAN: D @ 28.5" @ END A-44	EQUIPPED FOR UNIT BRAKE BEAMS, NARROW PEDESTAL ROLLER BEARING
AVE. LOAD LIMIT: 177,500 LBS.	SLACK ADJUSTER: SAB-42512-B DT&I DWG. Y-10172	WEIGHT OF TRUCK: 10,230#
	TOP END ANGLE: T @ 17.6" FT. CHANNEL-ASTM A36-4	WHEELS: 36" I WARE WROT STEEL H-36
	6" @ 15.3" FT. CHANNEL	
- BODY -	TOP SIDE ANGLE: T @ 17.6" FT. CHANNEL-ASTM A36-4	
AIR BRAKE MFG.: NEW YORK AIR BRAKE CO.	6" @ 15.3" FT. CHANNEL	
AIR BRAKE SCHEDULE: ABD 10 X 12	- TRUCK -	
BODY CENTER PLATE: 13 1/2" CAST INTEGRAL WITH 13 1/2" WEAR RING	BOLSTER: AAR CODE: NONE, B5C PAT. NO. B-10182	
BODY SIDE BEARING: PITT. FORGE SK-28154 DT&I DWG. X-9582	DWG. W-0948) AAR IDENT. NO. B-2040 ROLLER BEARING	
BULKHEADS: EVANS PRODUCTS DB-208301-C (4 PER CAR)	BOLSTER WEAR PLATE: HORIZONTAL: Z-6492	CARS: 9520-9549
CENTER SILL: 2; CZ-15 @ 41.2" FT. ASTM A-44	VERTICAL: Y-10326	D.T. & I.
CENTER SILL AREA: 24.24 SQ. IN.	BRAKE BEAM: 1/8" UNIT FOR COMP SHOES 188752	
COUPLER: E60C-A1 BOTT. OPER. DWG. X-10943	BRAKE SIDES: 2" HIGH REDUCION COMP RIF V-174	
COUPLER RELEASE RIGGING: STANRAY 10-23673-A (DT#1 DWG. Y-10967)	GENERAL DWG. & CTC 4486 - DT&I DWG. W-10950	MECHANICAL ENGINEERING DEPT. 8-25-72
CROSSOVER STEP: MORTON C102-III - DWG. X-10951	JOURNALS: 6 1/2" X 12" ROLLER BEARINGS	- REVISIONS -
CUSHIONING: KEYSTONE END OF CAR, DWG. T-D-1405-G	JOURNAL BEARINGS: TIMKEN 6 1/2" X 12" - 1-A	
	SIDE BEARINGS: STUCKI 688-B DWG. Y-5817	

-99 TON GONDOLA-

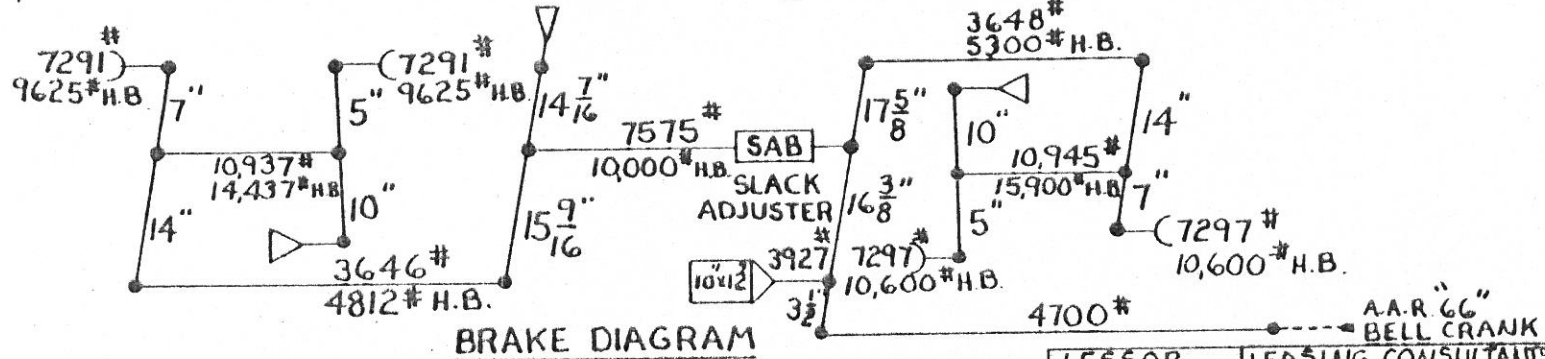
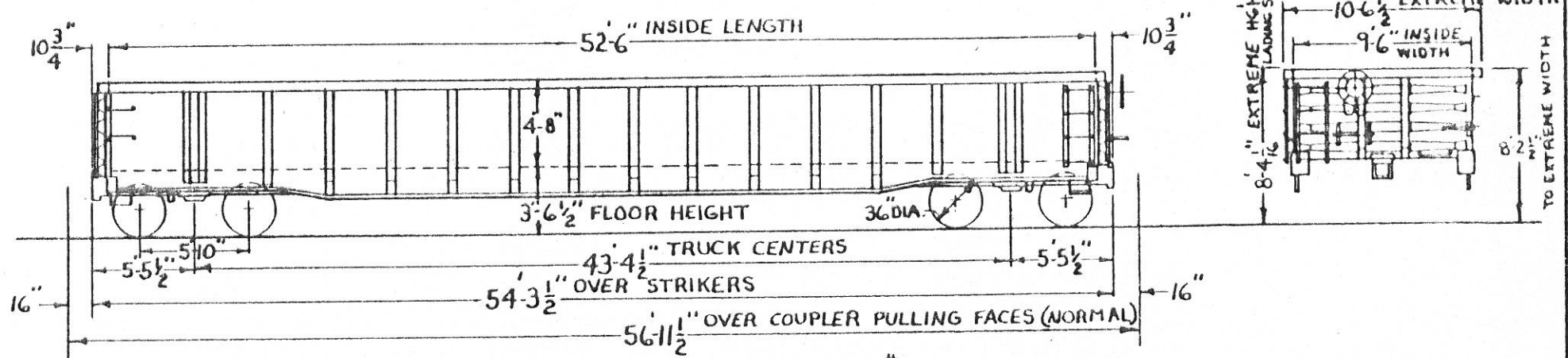

BRAKE DIAGRAM

	LESSOR	LEASING CONSULTANTS	LEASE 4380	TERM 12-31-86
- GENERAL -				
BUILDER: THRALL CAR MANUF. CO.	END SILL: 6" x 4" x 1/2" ANGLE ASTM A-36	SIDE BEARINGS: STUCKI 688-B (DT&I DWG. Y-5817)		
YEAR BUILT: 1971	FLOOR: PLATE 3/8" - AAR SPEC. M-116, COPPER BEARING	SIDE FRAMES: AAR CODE F95-OIBN-UA		
BUILDER'S REF.: 549	GENERAL ARR'G'T.: G-2068-B (DT&I DWG. W-10619)	B.S.C. PATT. NO. F-1064 (DWG. W-10088)		
AAR CLASS: GA	HAND BRAKE: AJAX 14665 (1966)	A.A.R. IDENT. NO.: B-986 - NARROW PEDESTAL		
NO. BUILT: 200	LADING BAND ANCHORS: ILL. R.Y. #7428 (W-10554)			
CAPACITY: 2325 CU. FT.	SIDE SILL: 6" x 4" x 5/8" ANGLE ASTM A-36	SPRINGS: ALCO AAR D-3, 14 OUTER AND 6 INNER		
AVE. LT. WT.: 63,300#	SLACK ADJUSTER: SAB DWG. 42512-A (DT&I DWG. YR112)	COILS PER TRUCK		
AVE. LOAD LIMIT: 199,700#	TOP END MEMBER: 6" x 6" x 5/16" TUBE ASTM A-500 GR. A	TYPE OF TRUCK: BARBER S-2-A, 6 1/2" x 12" STABILIZED		
	TOP SIDE MEMBER: 6" x 6" x 5/16" TUBE ASTM A-500 GR. A	EQUIPPED FOR UNIT BRAKE BEAMS, NARROW PEDESTAL ROLLER BEARING		
		WHEELS: 36" 2 WEAR CAST STEEL CJ-36		
- BODY -				
AIR BRAKE MFG.: NEW YORK AIR BRAKE	- TRUCK -			
AIR BRAKE SCHEDULE: ADD 10 x 12 (1-8)	BOLSTER: AAR CODE B95-08EJ-BX B.S.C. PATT.			
BODY CENTER PLATE: 13 3/4" DIA. CAST INTEGRAL	NO. B-10142 (DWG. W-10320) AAR IDENT. NO. B-1921			
WITH BOLSTER	ROLLER BEARING			
BODY SIDE BEARING:	BOLSTER WEAR PLATE: HORIZONTAL: Z-8692	CARS: 9600-9799		
CENTER SILL: 2" x 2" - 26 @ 41.2# FT. ASTM 512-50	VERTICAL: Y-10326			
CENTER SILL AREA: 24.24 SQ. IN.	BRAKE BEAM: *18 UNIT (FOR COMP. SHOES) APEX 196-G, DWG. X-674	D.T. & I.		
COUPLER TYPE: "E", 6" x 4" x 8", AAR NO. B-660B-HT	BRAKE SHOES: 2" COMPOSITION COMETH-4			
COUPLER RELEASE RIGGING: STANRAY 10-19019-F (DWG. Y-10362)	GENERAL DWG. DT&I DWG. W-10318	MECHANICAL ENGINEERING DEPT. OCT. 26, 1971		
DRAFT GEAR: MINER RF-321 (AAR SPEC. M-901-E)	JOURNALS: 6 1/2" x 12" ROLLER BEARING			
DRAFT GEAR ATTACH.: B-Y40-HT YOKE (HIGH TENSILE)	JOURNAL BEARINGS: TIMKEN 6 1/2" x 12" 1-A	- REVISION -		
ENDS: STANRAY 3E-23289-A (3/8") DWG. W-10363				

- 77 TON COVERED HOPPER -

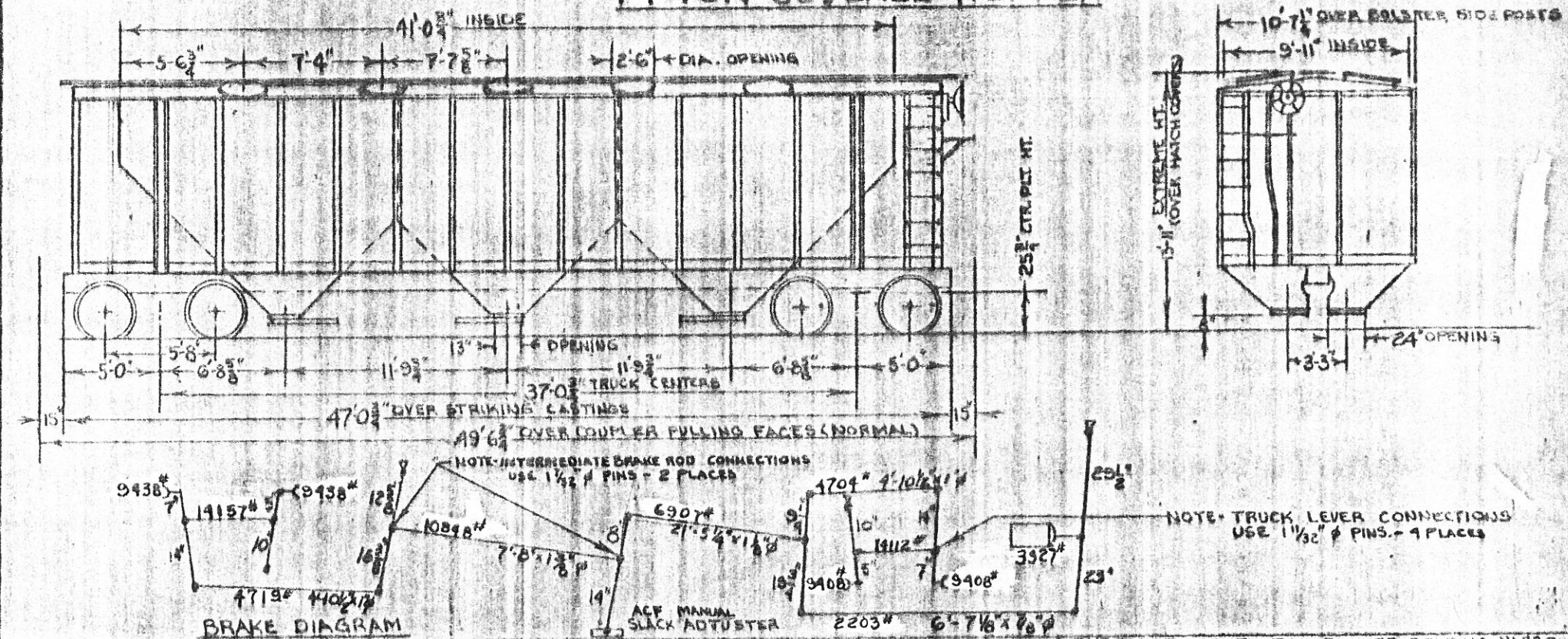

~ GENERAL ~		~ TRUCK ~											
BUILT BY- AMERICAN CAR AND FOUNDRY	DOOR FITURES, ROOF, CAR BUILDER	TYPE OF TRUCK- 70 TON, ROLLER BEARING, NARROW											
YEAR BUILT- 1961	DRAFT GEAR- NY-11-F CARDWELL-WESTINGHOUSE	PEDESTAL, RIDE CONTROL, SPRING PLANKLESS,											
BUILDERS REF- 8814	DRAFT GEAR ATTACHMENT GRADE B CEN YOKE Y-40	EQUIPPED FOR UNIT BRAKE BEAM.											
CAR CLASS- L0	END SILL ANGLE 6° 31' 23"	WHEELS 33" DIA, IWEAR WROT STEEL											
NO. BUILT- 78	GENERAL DRAWING- 58 CARS 7-CF 61-83201	WEIGHT- ONE BOLSTER											
CAPACITY- 5800 CU FT.	17 CARS ACF 61-92842 DT&I V-5800	ONE SIDE FRAME											
AVG. LT. WT- 62500 LBS.	HAND BRAKE- VERT WHL, ELLCON NAT. #148 DT&I W5828	ONE COMPLETE TRUCK 8,300 LBS.											
AVG. LOAD LIMIT 157,500 LBS.	RUNNING BOARD- APEX STEEL 8587A DT&I W5825												
	SIDE SILL BUILT UP- ANGLE 5° 31' 23"												
	SIDE BEARING CENTERS 4'-2"												
	SIDE PLATE- BULB ANGLE 4° 31' 23"												
~ BODY ~		~ CAR ~											
AIR BRAKE MFG. 58 CARS NY AB, 20 CARS WEST AD.	BEARINGS- TIMKEN ROLLER TYPE AP CLASS 6" G-11"	NOTE 1: THE FOLLOWING CARS EQUIPPED WITH "ENTERPRISE" PNEUMATIC DISCHARGE OUTLETS, 5/8" O.D.: 10038, 16059, 10072 (RAFFELS REMOVED)											
AIR BRAKE SCHEDULE AB1012	BOLSTER (N.R. CODE 87A-01E-B-H) SYM-WAYNE												
BODY CENTER PLATE- 13 3/8" FORGED STEEL	80 7159-AU DT&I W5837	CARS 10,000-10,074											
BODY SIDE BEARING- 4 1/2" PLT. AISI SPEC. E 1045	BRAKE BEAM UNIT #18												
CENTER SILL 2, 2, 26 AT 112 1/2" FT ROLLED SECTIONS	CENTER PLATE INTEGRAL	DT&I											
CENTER SILL AREA 30.12 SQ INCHES	GENERAL DRAWING: SYM-WAYNE R0768-C, DT&I W5838												
COUPLER TYPE 'E', HIT SLOTTED, BOTTOM OPERATED	JOURNALS- 6" I.I.	MOTIVE POWER DEPT. 5-27-62											
COUPLER RELEASE RIGGING- CAR BUILDER	SIDE BEARINGS- "STUCKI" 856 C DT&I Y-1470												
CYLINDER RELEASE VALVE- ORR	SIDE FRAME- PEDESTAL JAW, AAF CODE FA-GIAN-VA	REVISIONS											
DOORS HOPPER 88 CARS "KEYSTONE" (10000-10074)	SYM-WAYNE IFF-7153 DT&I W5830												
DOORS HOPPER 17 CARS "ENTERPRISE" (10038-10074)	SPRINGS- AAF D-3 2 1/2" TRAVEL 14 OUTER 2	<table border="1" style="width: 100%; height: 20px;"> <tr> <td>1/65</td> <td>5/70</td> <td></td> <td></td> <td></td> <td></td> <td></td> <td></td> <td></td> <td></td> </tr> </table>		1/65	5/70								
1/65	5/70												
DOORS ROOF CAR BUILDER	INNER COILS FOR TRUCK												
DOOR FITURES, HOPPER, "KEYSTONE" OR "ENTERPRISE"													

77-TON GONDOLA

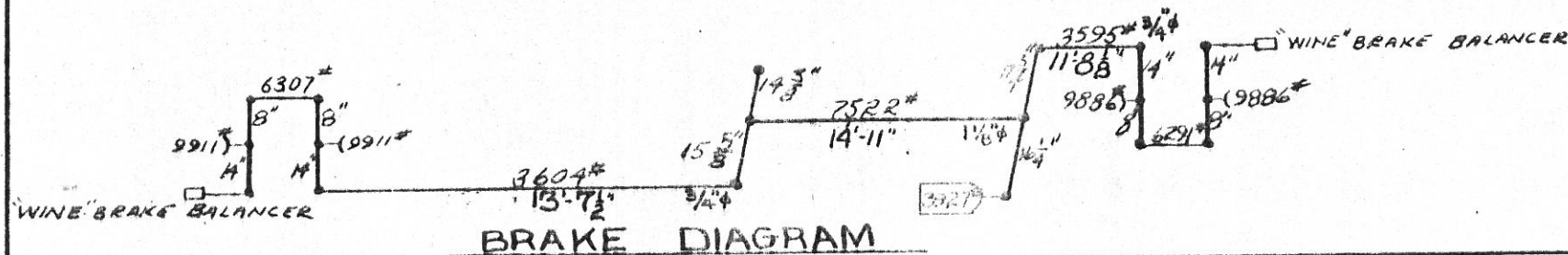
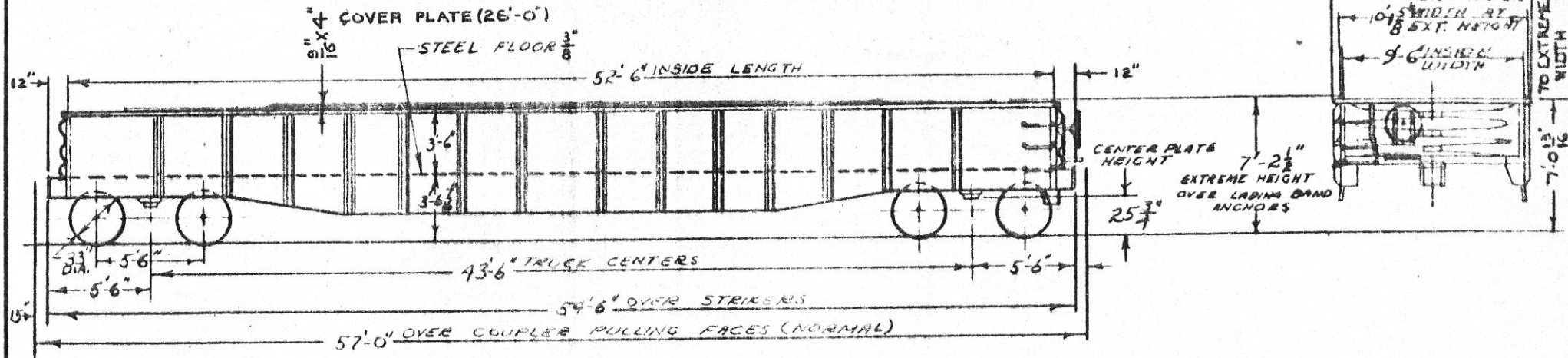

BRAKE DIAGRAM

GENERAL		FLOORING R 3/8" FLANGED																				
BUILDER - PULLMAN STD. CAR MFG. CO.	GENERAL PRVST. PULLMAN 523-F-1E REV. 4188																					
YEAR BUILT - 1957	HAND BRAKE VERTICAL WHEEL TYPE - UNIVERSAL																					
BUILDERS REF - 8365	LADING BAND ANCHORS - WINE RY EQPT. CO.																					
ARR. CLASS GB	SIDE SILL 6"x4"x3/8" L																					
NO. BUILT 100	SIDE BEARING CENTERS 4L2"																					
CAPACITY 1745 CUFT	TOP SIDE ANGLE 5" X 3" X 1/4" BULB ANGLE																					
AVG. LIGHT WT 55900#																						
AVG. LOAD LIMIT 164100#																						
BODY		- TRUCK -																				
AIR BRAKE MFG - WESTINGHOUSE	BOLSTER ARR CODE 87A-030-N-M-X																					
AIR BRAKE SCHEDULE AB-1912	BUCKET PAT. NO. 8-7069 (DRA. W-4961)																					
BODY CENTER PLATE - 13 3/4" DIA FORGED STL.	BRAKE BEAM - #18 UNIT TYPE - BUFFALO																					
BODY SIDE BEARINGS HARD STL - WEDGE SHAPED	GENERAL DWG. NSF71407C DTH W-4071																					
CENTER SILL - 2-2P6 @ 412" ROLLED SECTS.	JOURNAL 4"x11" BOX - INTEGRAL																					
CENTER SILL AREA (TOTAL SECT) 2424 SQ. IN.	JOURNAL BEARING - SEE NOTE																					
COUPLER TYPE 5' 6 3/8" 310TT6 BOTT. OPEP.	SIDE BEARING - SINGLE ROLLER STUCKI																					
COUPLER RELEASE RIG. PULLMAN ROTARY	SIDE FRAME ARR CODE F7A-024B-UR R5E																					
DRAFT GEAR - CARWELL WESTINGHOUSE NAT. F	PAT. NO. 81554 (DRA. W-3984)																					
DRAFT GEAR ATTACH. CAST STL YAKE	SPRINGS 3 3/4" TRVL HOG 1010 PER TRUCK																					
ENDS - FIXED PULLMAN 31A R	TYPE OF TRUCK 70T H321D CONTROL																					
END SILL 6" x 4" x 1/2" L	BEARING PLANKLESS - EQPT FOR UNIT BRAKE BEAMS																					
	WHEELS 12.0" RPT. STL.																					
	WEIGHT OF ONE TRUCK 9280#																					
		NOTE 2: CAR 9398 EQUIPPED WITH TIMKEN 6"x11" ROLLER BEARINGS, RAISED WHEEL SEAT AXLES, AND J-33 1-WEAR WROT STEEL WHEELS. ALL OTHER CARS EQUIPPED WITH PLAIN BEARINGS 6"x11"																				
		CARS: - 9300 - 9399																				
		DTE 1																				
		MOTIVE POWER DEPT. 10-23-57																				
		REVISION																				
		<table border="1" style="display: inline-table; border-collapse: collapse;"> <tr> <td style="width: 20px; height: 20px;"></td> <td style="width: 20px; height: 20px;"></td> <td style="width: 20px; height: 20px;"></td> <td style="width: 20px; height: 20px;"></td> <td style="width: 20px; height: 20px;"></td> <td style="width: 20px; height: 20px;"></td> <td style="width: 20px; height: 20px;"></td> <td style="width: 20px; height: 20px;"></td> <td style="width: 20px; height: 20px;"></td> <td style="width: 20px; height: 20px;"></td> </tr> <tr> <td style="text-align: center;">12/60</td> <td style="text-align: center;">1/65</td> <td style="text-align: center;">1/66</td> <td style="text-align: center;">5/70</td> <td style="text-align: center;">8/74</td> <td></td> <td></td> <td></td> <td></td> <td></td> </tr> </table>											12/60	1/65	1/66	5/70	8/74					
12/60	1/65	1/66	5/70	8/74																		