

NOTE 4 - ALL CARS EQUIPPED WITH PERFORATED FLOOR PLATES

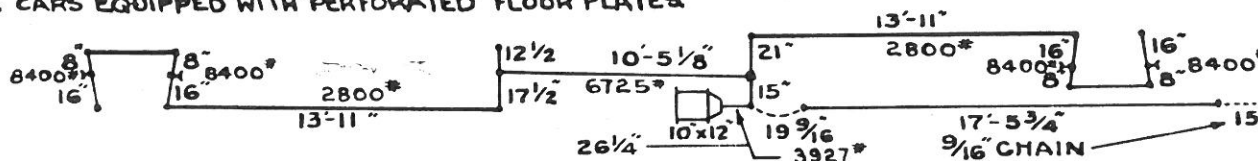

BRAKE DIAGRAM

NOTE NO. 1:- A.S.F. PATT. NO. 21367-B & B.S.C. PATT. NO. B-5068.
NOTE NO. 2:- A.S.F. PATT. NO. 21359-A & B.S.C. PATT. NO. F-5023.

GENERAL
BUILT BY:- BETHLEHEM STEEL CO.
YEAR BUILT:- 1937
BUIDER'S REF:- ORDER NO. 8942
R.R. SPEC. NO:- 100-A
A.A.R. CLASS:- XM
NO. BUILT:- 250
CAPY.- 4644 CU. FT.
AVERAGE LT. WT.- 57,300 LBS.
" LOAD LIMIT: 119,700 LBS.

BODY
AIR BRAKE MFG.- N.Y.A.B. Co.
" SCHEDULE:- AB.
BODY CTR. PLT.- 1 1/4" FORGED STEEL.
" SIDE BRG.- FORGED STEEL.
CENTER SILL:- C.B. Z-26 36.2 LBS.
" COVER PLT.- NONE.
" AREA:- 21.3 SQ. IN.
COUPLER:- "E" 6 1/4 x 8" SLOTTED BOTTOM OP.
" RELEASE RIG:- "IMPERIAL" ROTARY.
DOOR:- "YOUNGSTOWN" STAGGERED.
" FIXTURES:- "CAMEL" ROLLER LIFT.

DRAFT GEAR:- "NATIONAL" M-17-A. 2 3/4 TRAVEL.
" ATTACHMENT:- C.S. YOKE. B.S.C.
ENDS:- "DREADNAUGHT"
END SILL:- 5" x 3" x 3/8" L

FLOORING:- 2 1/4" T&G. (SEE NOTES 3&4)
GENERAL DRAWING:- C-25650-B. DT&I V-2453
HAND BRAKE:- "AJAX"
LINING- END:- 1 3/16" T&G.
" SIDE:- NONE.
ROOF:- WAGON TOP.
SIDE SILL:- 7" 18.8 LBS. L
" BRG. CENTERS:- 4'-2"
SHEATHING:- RIVETED STEEL.
SUPERSTRUCTURE:- STEEL.
WT. OF DOORS ON ONE SIDE OF CAR, WITH THE
FIXTURES MOUNTED ON THE DOORS:- 725 LBS.

TRUCK
BOLSTER:- SEE NOTE NO. 1.
BRAKE BEAM:- No. 15 "CRECO"
" SAFETY:- "CRECO" FOUR POINT.
CENTER PLATE:- INTEGRAL.
GENERAL DRAWINGS:- B.S.C. D-5310 & A.S.F. 56087.
JOURNAL:- 5 1/2" x 10"

JOURNAL BOX:- INTEGRAL.
R.R. SPEC. NO:- 102.
SIDE BEARING:- O.H. STEEL.
" FRAME:- SEE NOTE NO. 2.
SPRINGS:- S.G. DRAWING R-5006. C.E.
TYPE OF TRUCK:- SPRING PLANKLESS WITH
BRACKET FOR BRAKE BEAM SAFETY CAST
INTEGRAL AND "MOBIL" RETAINER.
WHEELS:- ONE WEAR WROT STEEL.
WEIGHT OF A.S.F. BOLSTER:- 860 LBS.
" B.S.C. " 845 LBS.
" A.S.F. SIDE FRAME:- 615 LBS.
" B.S.C. " 635 LBS.
" ONE TRUCK:-

CARS:- 13000-13249

D.T. & I.

MOTIVE POWER DEPT. 9-1-42
REVISION
11/57 2/20 5/62 1/65
FSM RN FAM

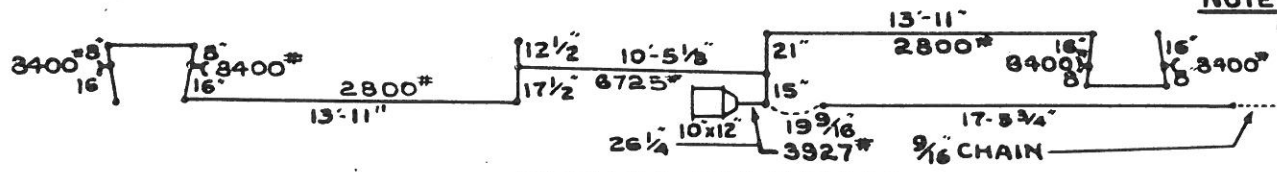
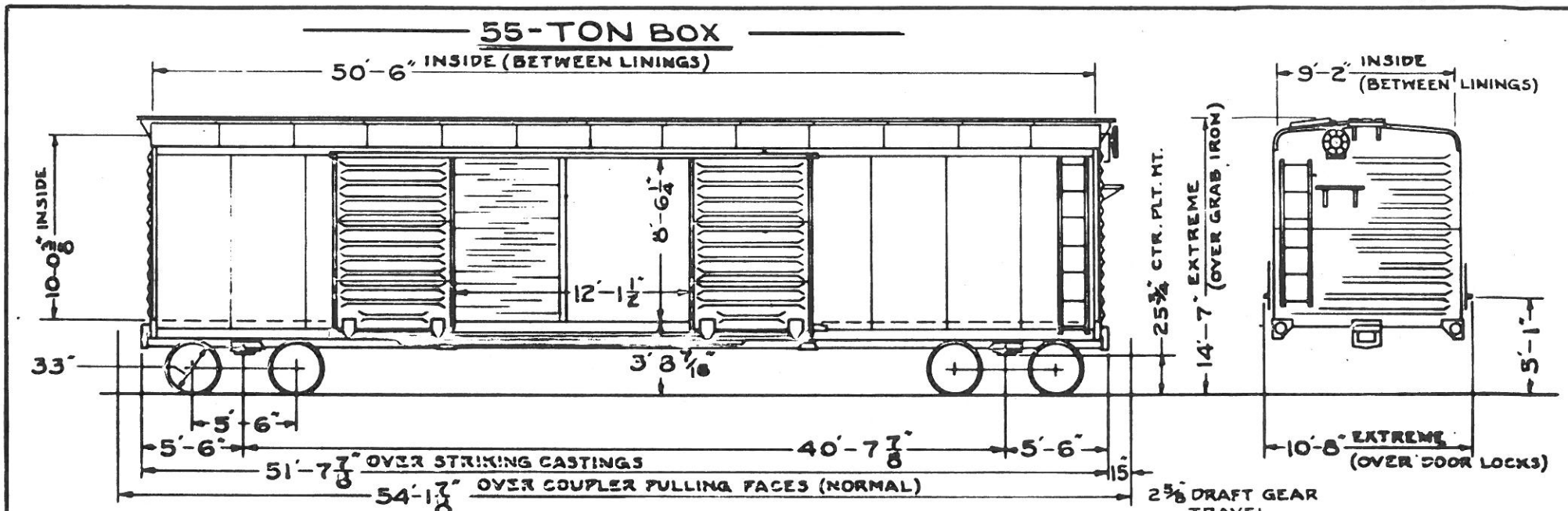

BRAKE DIAGRAM

NOTE 1: FOLLOWING CARS EQUIPPED WITH G.L.S. TRAVEL. AVAILABLE STEEL FLOOR: 13523

GENERAL		DRAFT GEAR: - CARDWELL-HESTINGHOUSE NY-11-E.		JOURNAL BOX: - INTEGRAL.	
BUILT BY: - BETHLEHEM STEEL CO.		" " ATTACHMENT: - C.S. YOKE. B.S.C.		R.R. SPEC. NO. - 102	
YEAR BUILT: - 1937		ENDS: - "DREADNAUGHT"		SIDE BEARING: - O.H. STEEL.	
BUILDER'S REF. - ORDER NO. 8941.		END SILL: - 5" x 3" x 3/8" L		FRAME: - A.S.F. PATT. NO. 21359-A.	
A.A.R. CLASS: - XL		FLOORING: - 2 1/4" T&G. (SEE NOTE 1)		SPRINGS: - S.O. DRAWING R-5003, C.E.	
NO. BUILT: - 100		GENERAL DRAWING: - C-25573-B, DT81V-2454		TYPE OF TRUCK: - SPRING PLANKLESS WITH	
R.R. SPEC. NO. - 100		HAND BRAKE: - "UNIVERSAL" TYPE XL.		BRACKET FOR BRAKE BEAM SAFETY CAST	
AVERAGE LT. WT. - 57,300 LBS.		LINING - END: - 1 1/16" T&G.		INTEGRAL AND "MOBIL" RETAINER.	
" LOAD LIMIT: - 119,700 LBS.		" SIDE: - 1 3/4" S.L. & 1 1/16" T&G.		WHEELS: - ONE WEAR WROT STEEL.	
CAPY. - 4644 CU. FT.		ROOF: - WAGON TOP.		WEIGHT OF BOLSTER: - 850 LBS.	
BODY		SIDE SILL: - 7" - 18.8 LBS. L.		" " SIDE FRAME: - 615 LBS.	
AIR BRAKE MFG. - N.Y.A.B. CO.		" H&G. CENTERS: - 4'-2"		" " ONE TRUCK: -	
" SCHEDULE: - AB.		SHEATHING: - RIVETED STEEL.			
BODY CTR. PLY. 1 1/4" FORGED STEEL.		SUPERSTRUCTURE: - STEEL.			
" SIDE BRG. - FORGED STEEL.		INT. OF DOORS ON ONE SIDE OF CAR, WITH THE			
CENTER SILL: - C.B. Z-26 36.2 LBS.		FIXTURES MOUNTED ON THE DOORS: - 725 LBS.			
" COVER PLY. - NONE.		TRUCK		CARS: - 13500-13599	
" AREA: - 21.3 SQ. IN.		BOLSTER: - A.S.F. PATT. NO. 21367-B.		D.T. & I.	
COUPLER: - "E" & "A" SLATED BOTTOM OP.		BRAKE BEAM: - NO. 15 CONC.		MOTIVE POWER DEPT. 9-1-42	
" RELEASE RIG. - "IMPERIAL" ROTARY.		" " SAFETY: - "E" & "C" FOUR POINT.		REVISION	
DOOR: - "YOUNGSTOWN" STAGGERED.		CENTER PLY. - INTEGRAL.		11/57 12/60 3/62 1/65 5/70	
" FIXTURES: - "CAMEL" ROLLER LIFT.		GENERAL DRAWING: - C-21307-B.			
		JOURNAL: - 8 1/2" x 18"			

55 TON BOX

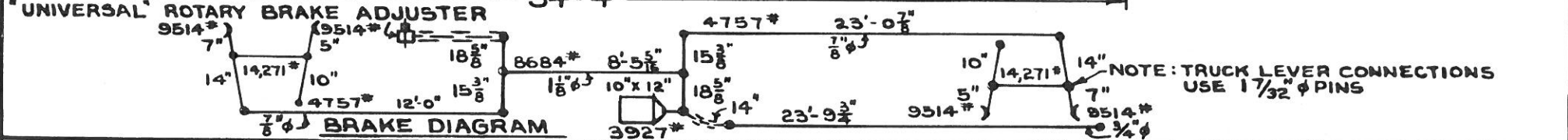
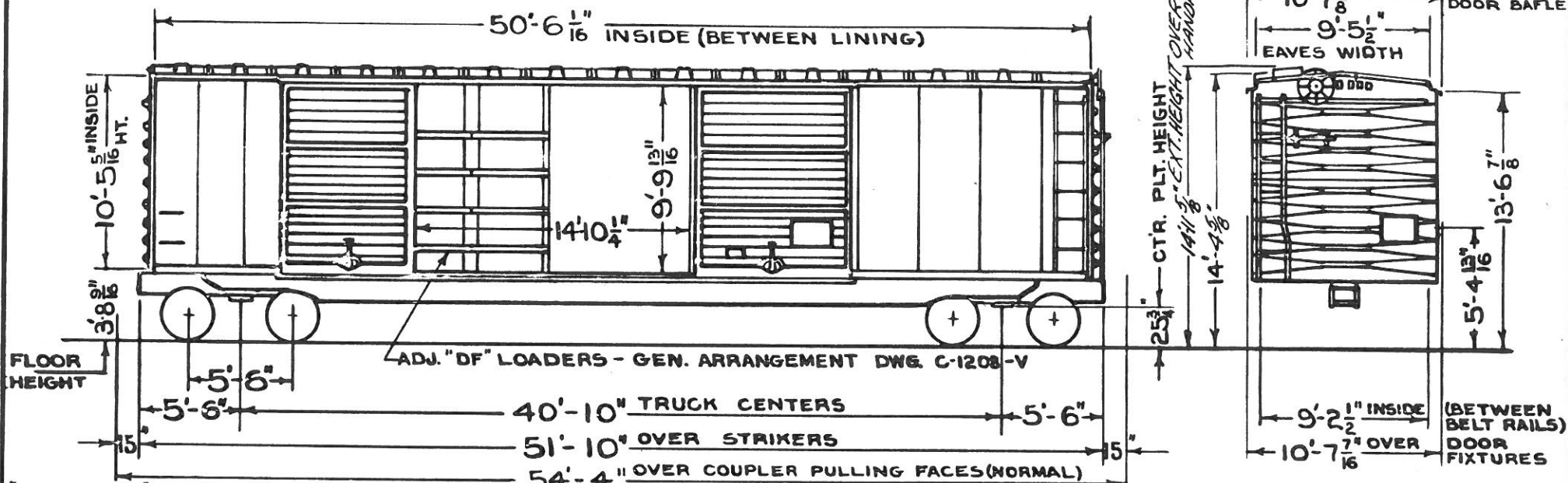

GENERAL		TRUCK	
BUILT BY: PULLMAN-STANDARD	DRAFT GEAR: 50 5/8 MINER A-22-XL	JOURNALS: 5 1/2" x 10" TRUCK WEIGHT 7950#	
YEAR BUILT: 1950	50 5/8 CARDWELL-WEST. NY-11-F	JOURNAL BOX: 15400-15449 INTEGRAL	
BUILDERS REF.: 8396	DRAFT GEAR ATTACHMENT: GRADE "B" C.S. YOKE (P-40)	15450-15499 NONE	
A.A.R. CLASS: XL	ENDS: PULLMAN, TOP SHEET 3/16", BOT. SHEET 5/16"	(NARROW PEDESTAL ROLLER BEARING)	
NO. BUILT: 100	END SILL: NONE, (BOTTOM END SHEET FLANGED)	SIDE BEARINGS: STUCKI 656-C	
CAPY.: 4856 CU.FT. (WITH BELT RAIL IN)	FLOOR: 3/16" STEEL PLATE OVER 2 1/4" x 5 1/16" OR T" C.M.	SIDE FRAME: 15400-15449, AAR CODE: 153-0228-1/A	
4920 CU.FT. (WITHOUT BELT RAIL)	GENERAL DWG. PULL. STD. 527-F-14-A, DT&I V-5356	ASF PAT. NO. 21754-U (DT&I DWG. W-5274)	
AVE. LT. WT.: 57,700 (WITH NO. OF EQUIP)	HAND BRAKE: MINER, D-3290-XL	AAR IDENT. NO. 682	
AVE. LOAD LIMIT: (DEPENDS ON CAR COMP)	LINING: END, 25/32" T&G	15450-15499, AAR CODE: 153-0228-1/A	
AVE. LT. WT. 60400 (WITH PERMANENT D-F EQUIP WELDED TO CAR BODY)	ROOF: PULLMAN	ASF PAT. NO. 21894-A (DT&I DWG. W-5273)	
BODY		AAR IDENT. NO. 795	
AIR BRAKE MFG.: SECOND HAND	SIDE SILL: 6" x 6" x 3/8" ANGLE	SPRINGS: 2 1/16" TRAVEL, AAR D-5	
AIR BRAKE SCHEDULE: AB 1012	SIDE BEARING CENTERS: 4'-2"	TYPE OF TRUCK: 50 TON, BARBER S-2-C	
BODY CENTER PLATE: 11 3/4" DROP FORGED	SIDE PLATE: ROLLED "Z" U.S. STEEL SECT. Z-281	STABILIZED, SPRING PLANKLESS, UNIT	
BODY SIDE BEARING: CARNEGIE-ILL. SECT. M-4198	SIDE SHEATHING: 0.10" C.B.S. WELDED	WHEELS: 2 WEAR CAST STL. 33"	
CENTER SILL: 2, Z-260 4.12 1/2 PT. ROLLED SECT. S	CARS: 15400-15499		
CENTER SILL AREA: 24.24 SQ. IN.	D.T. & I.		
COUPLER: TYPE "E", 6 1/4" x 8", SLOTTED, BOTTOM OPR.	MOTIVE POWER DEPT. 12-8-60		
COUPLER RELEASE RIGGING: PULLMAN	- REVISIONS -		
CYLINDER RELEASE VALVE: SLOAN-CACO 1200A	5/62 2/65 6/70 8/74		
DOORS: YOUNGSTOWN NO. 47 TYPE DWG. V-5308	FAM		
DOOR FIXTURES: "CAMEL" ROLLER LIFT	GENERAL DWG.: STD. CAR TRK. 3350-B (PLAIN BEAR)		
	STD. CAR TRK. 3522-B (ROLLER BEAR)		

NOTE: TRUCK LEVER CONNECTIONS USE 1 7/32" PINS

77 TON BOX

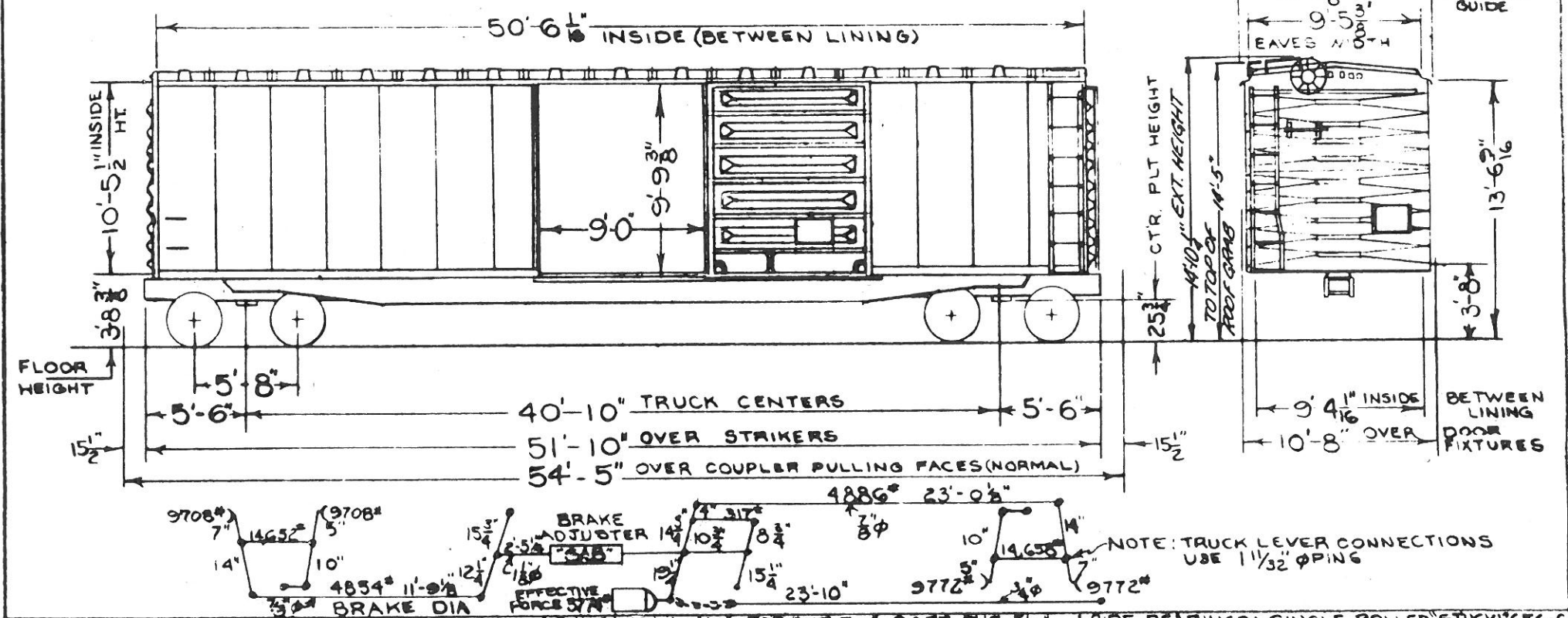

<p align="center">~GENERAL~</p> <p>BUILT BY: PULLMAN STANDARD YEAR BUILT: 1963 BUILDERS REF: 8782 AAR CLASS XM NO. BUILT: 200 CAPY: 4932 CU. FT. AVE. LT. WT: 57,700 AVE. LOAD LIMIT: 162,300</p>		<p>ENDS: PULLMAN TOP SHT. 3/16", BOTT. SHT. 1/16" UND SILL: NONE (BOTTOM END SHT. FLANGED) FLOOR: 2 1/4" x 5 1/2" @ 7" CENTER MATCHED GENL. DWG: PULLMAN 834-F-31A, DT#1 V-6386 HAND BRAKE: 100% AJAX CONS. 100% KLASING LINING: END 20/32 T&G, SIDE 25/32" T&G ROOF: PULLMAN</p>		<p>SIDE BEARINGS: SINGLE ROLLER "STUCKI" 656-C SIDE FRAMES: ASF PATT. 21980-M WITH WASTE RETAINING RIBS, INTEGRAL BOX, AAR CODE F75-048B-UA, AAR IDENT. NO. 904, DT#1 DWG. W-5959</p>	
<p align="center">~BODY~</p> <p>AIR BRAKE MFG: SECOND HAND AIR BRAKE SCHEDULE: AB1012 BODY CENTER PLATE: 13 3/4" DROP FORGED BODY SIDE BEARING: CARNEGIE ILL. SECT M4198 CENTER SILL: 2, 2 26 @ 41.2" FT ROLLED SECS CENTER SILL AREA: 24.24 SQ IN. COUPLER: TYPE B-E-60A-HT COUPLER RELEASE RIGGING: PULLMAN CYLINDER RELEASE VALVE: WESTINGHOUSE QRR DOORS: PULLMAN DT#1 DWG. V-6402 DOOR FIXTURES: PULLMAN DRAFT GEAR: 100% MINER A 22XL 100% CARDWELL-WEST. NY-11-F DRAFT GEAR ATTCHMT. GRADE B C.S. YOKE (Y-40)</p>		<p>SIDE SILL: 6 x 6 x 3/4" ANGLE SIDE BEARING CENTERS: 4'-2" SIDE PLATE: HOLLOW 1" US STL. SECT. S-281 SIDE SHEATHING: 0.10 CBS WELDED</p>		<p>SPRINGS: 3HG" TRAVEL, AAR D4 TRUCK WT: 8620 TYPE OF TRUCK: TONON, BARBER S2B STABILIZED, SPRING PLANKLESS EQPT. FOR UNIT BRAKE BEAM</p>	
<p align="center">~TRUCK~</p> <p>BOLSTER: 100% BUCKEYE PATT. B7145 DT#1 W-5961 AAR CODE B75-04EB-BN 100% NATIONAL PATT. 37831-17 DT#1 W-5962 AAR CODE B75-04EB-BN BRAKE BEAM: UNIT NO. 18 100% BUFFALO 100% CH. RWY. EQPT. CENTER PLATE: INTEGRAL GENL. DWG: STD. OR. TRK. 3740-A, DT#1 W-5943 JOURNALS: 6" x 11" WITH FLAT BACK BEARINGS JOURNAL BOX: INTEGRAL</p>		<p>CARS 16500-16699</p> <p align="center">DT & I</p> <p>MOTIVE POWER DEPT. 5-17-63</p> <p align="center">REVISIONS</p>		<p>2/65 3/65</p>	

NOTE: TRUCK LEVER CONNECTIONS USE 1 1/32" PING

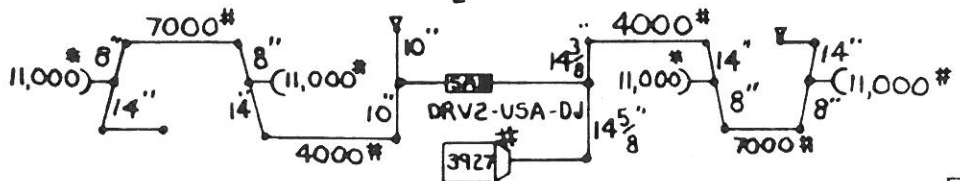
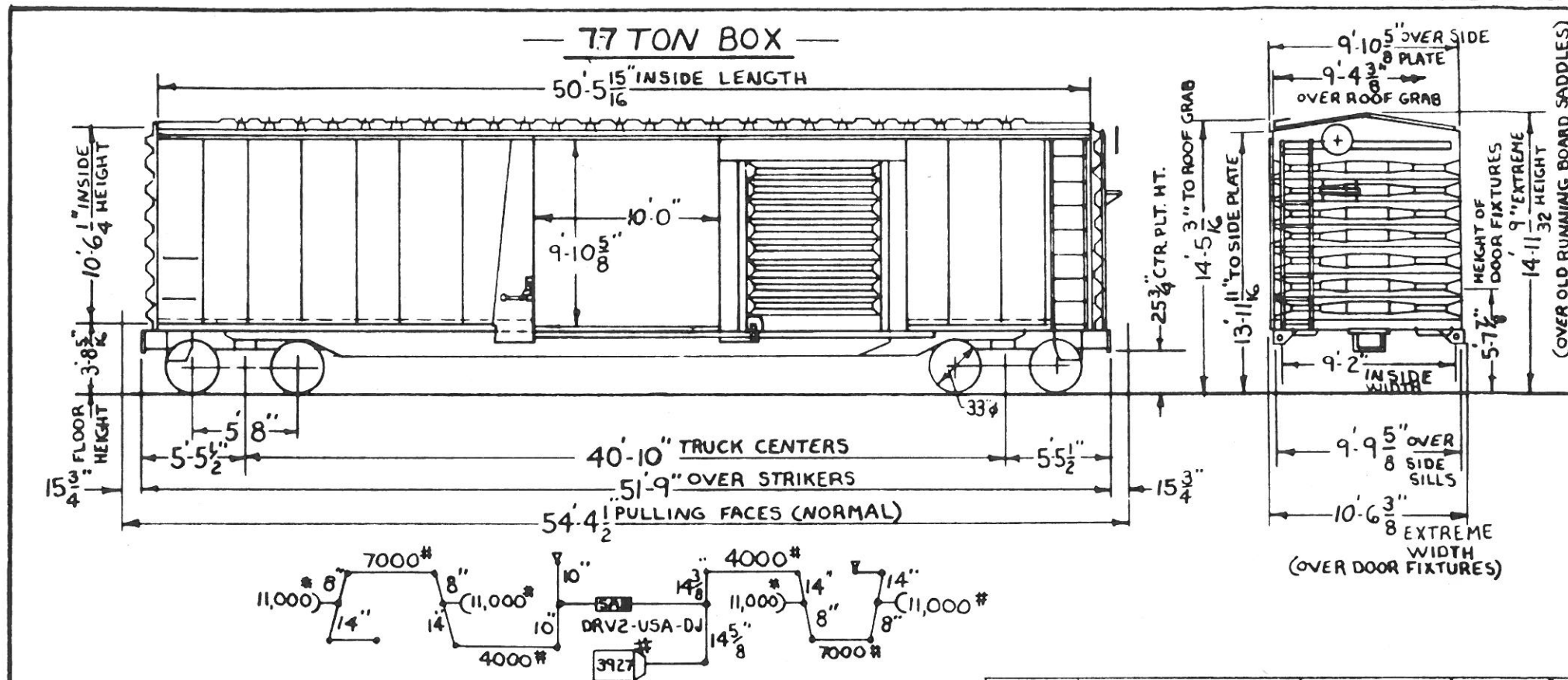

- GENERAL -		LESSOR CHICAGO FREIGHT CAR LEASE: 4377 TERM: 1-2-87
BUILDER: GENERAL AMERICAN TRANS. CO.	SHEET 1/4" (SE-8136-B) DT&I V-1465	SIDE FRAME: (CARS 16800-16844) AAR CODE F75-048B-UA ASF PATT. NO. 21980-A AAR IDENT. NO. 304 (DT&I DWG. W-5454)
YEAR BUILT: 1951 GATC REBUILT: 1971	FLOORING: 2 1/4" VERTICAL GRAIN LAMINATED IN DOOR-WAY, HORIZONTAL LAMINATE IN ENDS	SIDE FRAME: (CARS 16845-16899) AAR CODE F7A-02AB-SA ASF PATT. NO. 21655-C AAR IDENT. NO. 304 (DT&I DWG. W-10550)
BUILDERS REF: 8022 (GATC)	GENERAL DWG.:	(BOTH FRAMES MODIFIED FOR ROLLER BEARING APPLICATION PER DT&I DWG. W-9547)
A.A.R. CLASS: XM	HAND BRAKE: AJAX #13396	SPRINGS: (CARS 16800-16844) AAR D-4 14 OUTER AND 4 INNER COILS PER TRUCK 3 1/16" TRAVEL (CARS 16845-16899) AAR D-5 3 1/16" TRAVEL 14 OUTER & 12 INNER PER TRUCK
NO. REBUILT: 100 CHICAGO FREIGHT CAR	LINING: END: STEEL STD. RY. EQUIP. SIDE: 3/4" PLYWOOD	TYPE OF TRUCK: (CARS 16800-16844) 70 TON BARBER 5-2-B EQUIPPED FOR UNIT BRAKE BEAMS (CARS 16845-16899) 70 TON A-3 RIDE CONTROL EQUIPPED FOR HANGER TYPE BRAKE BEAMS
CAPY: 4870 CU. FT.	ROOF: STD. RY. EQUIP. TR-8418-B (DT&I V-1464)	WHEELS: 33" ONE WEAR CAST STEEL - CJ33
AVE. LT. WT.: 62,500 LBS.	SIDE SHEETS: .01" C.B.S.	
AVE. LD. LT.: 157,500 LBS.	SIDE SILL: 6" X 6" X 3/8" ANGLE	
	SIDE SILL REINF: 15" @ 40.0#/FT CHANNEL	
- BODY -	SLACK ADJUSTER: SAB DRV2-USA-DJ	
AIR BRAKE MFG. NEW YORK AIR BRAKE	- TRUCK -	
AIR BRAKE SCHEDULE: ABD 10X12 CYLINDER	BOLSTER: (CARS 16800-16844) AAR CODE B75-048B-BA ASF PATT. NO. 21732-A AAR IDENT. NO. 1192 (DT&I DWG. W-6408)	
BODY CTR. PLATE: 133/4" CAST INTEGRAL WITH BOLSTER	BOLSTER: (CARS 16845-16899) AAR CODE B7A-03BB-BJ ASF PATT. NO. 21704-S AAR IDENT. NO. 1227 (DT&I DWG. W-10549)	
BODY SIDE BEARING: 5/8" X 4" - 1045 STEEL-WELDED	BRAKE BEAM: #18 (CARS 16800-16844) UNIT (CARS 16845-16899) HANGER TYPE	
CENTER SILL: 2-36 2 1/4" ROLLED ZEE SECTION	GENERAL DWG. (CARS 16800-16844) X-418 (CARS 16845-16899) W-	
CENTER SILL AREA: 21.3 SQ. IN.	JOURNAL: 6" X 11" ROLLER BEARING	
COUPLER: B-EGO BHT BOTTOM OPERATED	JOURNAL BEARINGS: BRENCO 5-A 6" X 11"	
COUPLER RELEASE RIGGING: STD. RY. EQ. #875 (DT&I DWG. V-10386)	JOURNAL BEARING STOP BLOCKS: AZEE (DT&I DWG. W-10555)	
DOOR: YOUNGSTON 14467-B DT&I DWG. V-10386	SIDE BEARING: STUCKI G56-C (DT&I DWG. Y-1470)	
DRAFT GEAR: CARDWELL-WESTINGHOUSE NY-11-F		
DRAFT GEAR ATTACH: B-Y40 CAST STEEL NAT'L CAST		
ENDS: STD. RY. EQUIP. TOP SHEET 3/16" BOTTOM		

CARS: 16800-16899

DT&I

MECHANICAL ENGINEERING DEPT. NOV. 8, 1971

- REVISIONS -

77 TON BOX CAR

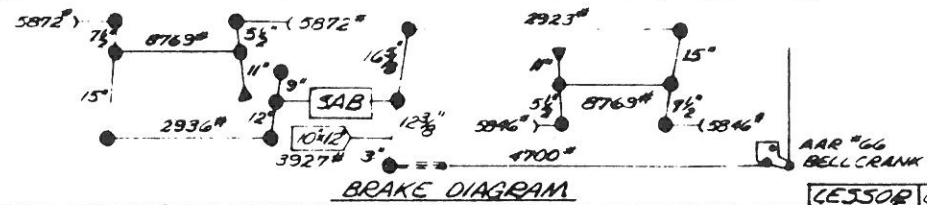
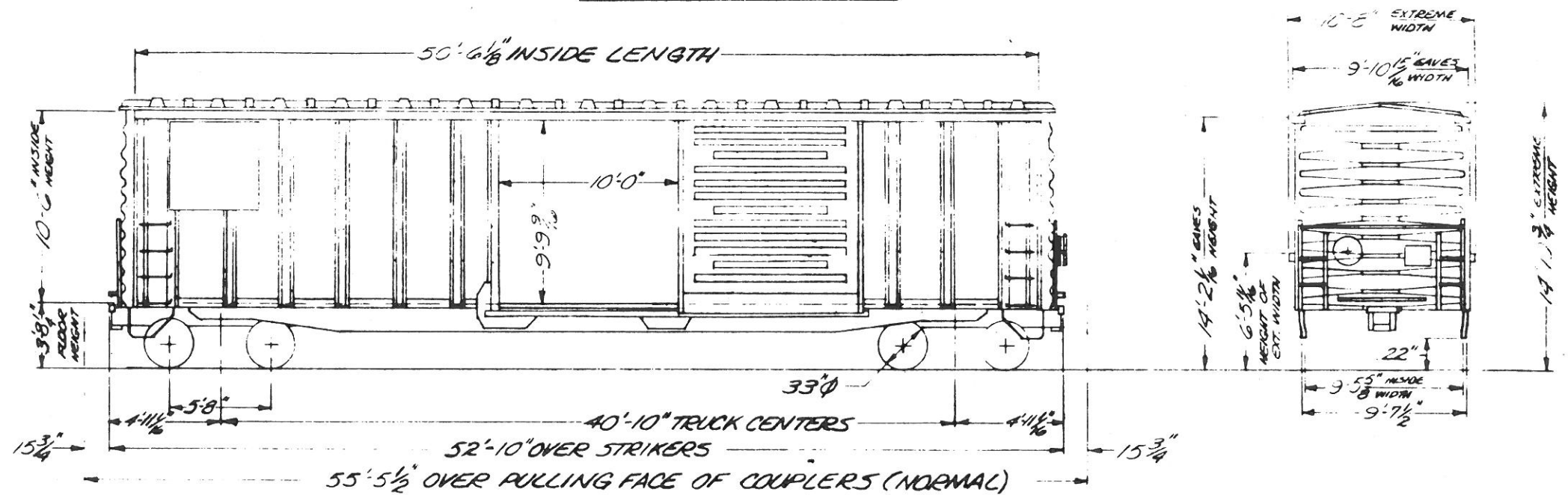

NOTE: BRAKE FORCES SHOWN ARE THEORETICAL
SHOE TEST SHOWS: 68.0% EFF. FOR CYLINDER
126% EFF. FOR HAND BRAKE

— GENERAL —		LESSOR	GREYHOUND LEASING	LEASE 4507	TERM: 2-1-89
BUILDER: PULLMAN-STANDARD (BESSEMER)	END SILL: NONE (BOTTOM END SHEET FLANGED)	A.A.R. IDENT. NO. B-866 NARROW PEDESTAL			
YEAR BUILT: 1973	FLOOR: 2 1/2" x 5 1/8" YELLOW PINE (50X FORK LIFT AXLE LOAD)	SPRINGS: A.A.R. D-5, 14 OUTER & 8 INNER COILS PER TRUCK, 3 1/2" TRAVEL (HENRY MILLER)			
BUILDERS REF.: LOT 9696	GENERAL DWG.: P.S.C. M-042-582 (OTRI)	SIDE SPRINGS: (OTRI X-3426)			
A.A.R. CLASS: XM	HAND BRAKE: AJAX 14665-1	TYPE OF TRUCK: BARBER 5-2-C 6" x 11" STABILIZED			
CAPACITY: 5022 CU. FT.	UNING: SIDE-NONE	EQUIPPED FOR UNIT BRAKE BEAM,			
AVE. LT. WT. 55,800 LBS.	END - 3 1/4" PLYWOOD AC FIR	NARROW PEDESTAL, ROLLER BEARING			
AVE. LOAD LIMIT 164,200 LBS.	ROOF: PULLMAN-STD. R-002-436 (OTRI DWG. V-11167)	WEIGHT OF ONE TRUCK: 9040 LBS.			
— BODY —		WHEELS: 33" DIA. 2 WEAR CAST STEEL CM-33			
AIR BRAKE MFG.: NEW YORK AIR BRAKE	SIDE PLATE: 1/4" PRESSED ZU SECTION				
AIR BRAKE SCHEDULE: ABD VALVE 10x12" CYLINDER	SIDE SHEETS: 1/8" @ 0008 1/16 BEND, 10" INTERMEDIATE				
2" HIGH FRICTION COMPOSITION BRAKE SHOES	SIDE SILL: 6" x 4" x 3/8" ANGLE ASTM A-441				
BODY CENTER PLATE: 13 3/4" DROP FORGED (PULLMAN U-121-098)	SIDE SILL REINFORCEMENT: 1/4" AND 3/8" PRESSED ANGLE				
— TRUCK —					
BODY SIDE BEARING: ROLLED SECTION - HEAT TREATED	BOLSTER: A.A.R. CODE - B75-08EB-BV, BUCKEYE				
CENTER SILL: 2, C 213 @ 41.2" FT. ROLLED ZEE ASTM A-441	PATT. NO. B-7143 (OTRI W-11190) A.A.R.				
CENTER SILL AREA: 24.24 SQ. IN.	IDENT. NO. B-1770 (RB)				
COUPLER: EGOCHT	BRAKE BEAM: #15 UNIT (FOR COMPOSITION SHOES)				
COUPLER RELEASE RIGGING: PULLMAN-STD.	BUFFALO				
CROSSOVER STEP: MORTON C-102-132 (OTRI DWG. X-11172)	BRAKE SHOES: 2" HIGH FRICTION COMP. (COMET H-A)				
DOORS: PULLMAN-STD. D-025-193-B (OTRI)	GENERAL DWG.: STD. CAR TRUCK 3741-M (OTRI X-11164)				
DRAFT BEAR: MINER RF-444 (AAR M-901-E SPEC.)	JOURNALS: 6" x 11" ROLLER BEARINGS				
DRAFT BEAR ATTACHMENT: C.S. YOKO Y404HT	JOURNAL BEARINGS: NEW DEPART. HAVT 6" x 11" G-A				
ENDS: PULLMAN-STD. TOP SHEET 3/16" QHS	SIDE BEARINGS: STUCKI 638-C (OTRI Y-1470)				
BOTTOM 1/4" ASTM A-441	SIDE FRAME: A.A.R. CODE - FTS-04BN-UN BUCKEYE				
	PATT. NO. F-7214 (OTRI W-11189)				
		CARS: 16900-16974			
		D.T.E.I.			
		MECHANICAL ENGINEERING DEPT. 1-16-74			
		— REVISIONS —			

75 TON BOX CAR

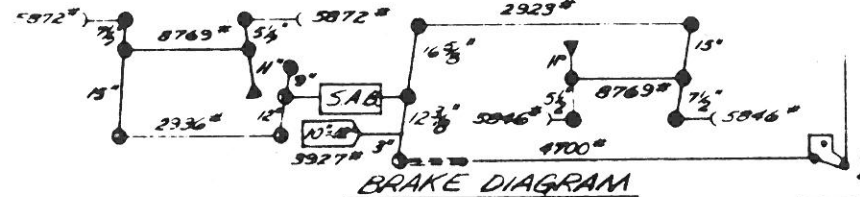
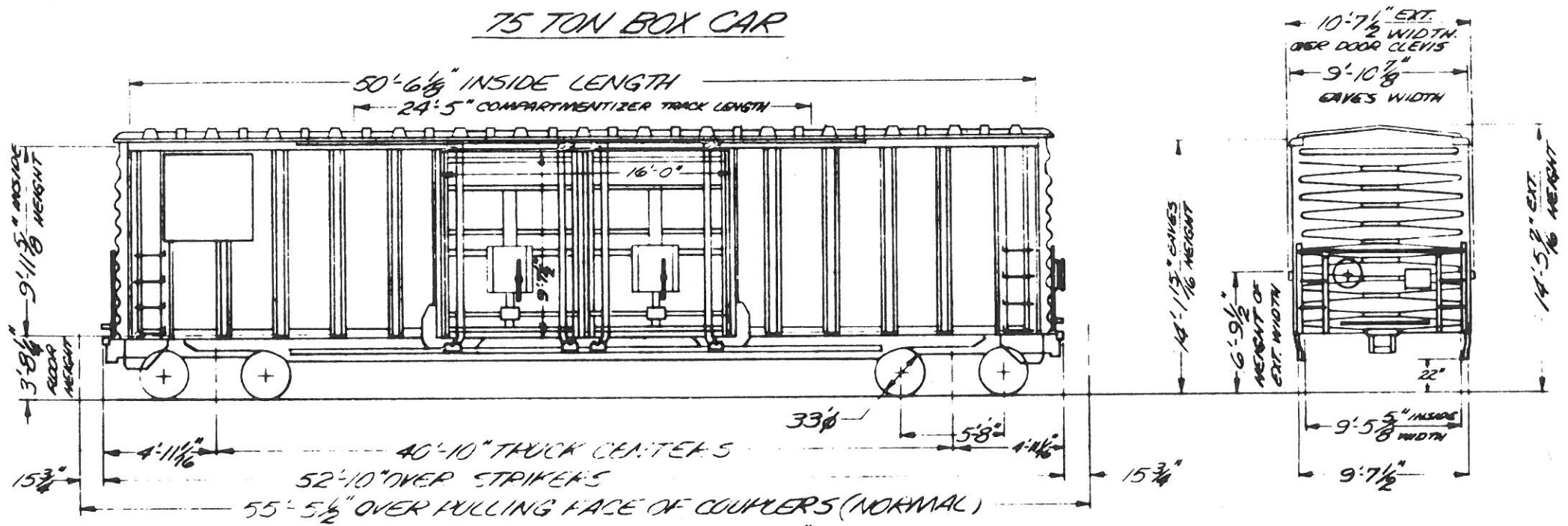

NOTE: BRAKE FORCES SHOWN ARE THEORETICAL
 SHOE TEST SHOWS 68.2% EFF. FOR CYLINDER
 120.0% EFF. FOR HAND BRAKE

LESSOR GREYHOUND LEASING LEASE: 4507 TERM: 2-1-89	
— GENERAL —	
BUILDER: PULLMAN-STANDARD (BESS, EMER)	DOOR BASKET: YOUNGSTOWN - MAIN Y-55430, AUX. Y-55431
YEAR BUILT: 1973	DRAFT GEAR: CARDWELL - WESTINGHOUSE MARK 50
CYLINDERS REF: LOT 5697	A.A.R. SPEC. M-901-E (D.T. & I. DWG. W-11193)
A.A.R. CLASS: XF	DRAFT GEAR ATTACHMENT: G.S. YORK Y-101AHT
CAPACITY: 4767 CU. FT.	ENDS: PULLMAN-STD.: TOP SHEET - 1/4\"/>
AVE. CT. WT.: 68,800 LBS.	1/4\"/>
AVE. LOAD LIMIT: 151,200 LBS.	ENDSILL: NONE (BOTTOM END SHEET FLANGED)
	FLOOR: 2 1/8\"/>
	GENERAL DWG. PULL: STD. M-042-590 (D.T. & I. DWG.)
	HANDBRAKE: UNIVERSAL 7400-3
	LINING: SIDE - NONE, END - 3/4\"/>
	ROOF: PULL: STD. R-002-437 (D.T. & I. DWG. V-11177)
	SIDE PLATE: 14\"/>
	SIDE SHEETS: 3/16\"/>
	SIDE SILL: 6\"/>
	SIDE SILL REINF.: 15\"/>
	SLACK ADJUSTER: SAB DRV2-USA-DJ (D.T. & I. DWG. Y-11222)
	— TRUCK —
	BOLSTER: A.A.R. CODE B75-002B-0N, BUCKEYE
	PATTERN NO. B-7145 (D.T. & I. W-11190) A.A.R.
	IDENT. NO. B-1720 (R.B.)
	BRAKE BEAM: 18 UNIT (FOR COMP. SHOES) BUFFALO
	BRAKE SHOES: 2\"/>
	GENERAL DWG: STD. CAR TRUCK 3741-M (D.T. & I. DWG. X-11164)
CARS: 17000-17074	
D.T. & I. MECHANICAL ENGINEERING DEPT. 3-7-74	

77 TON BOX -

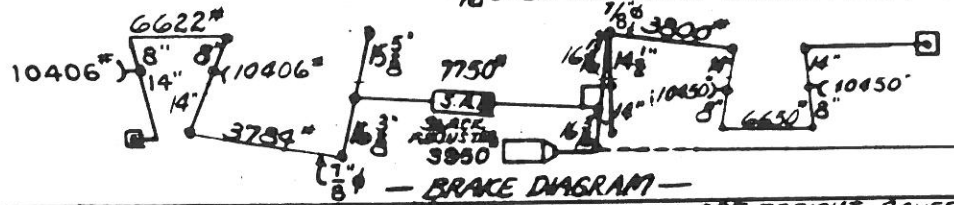
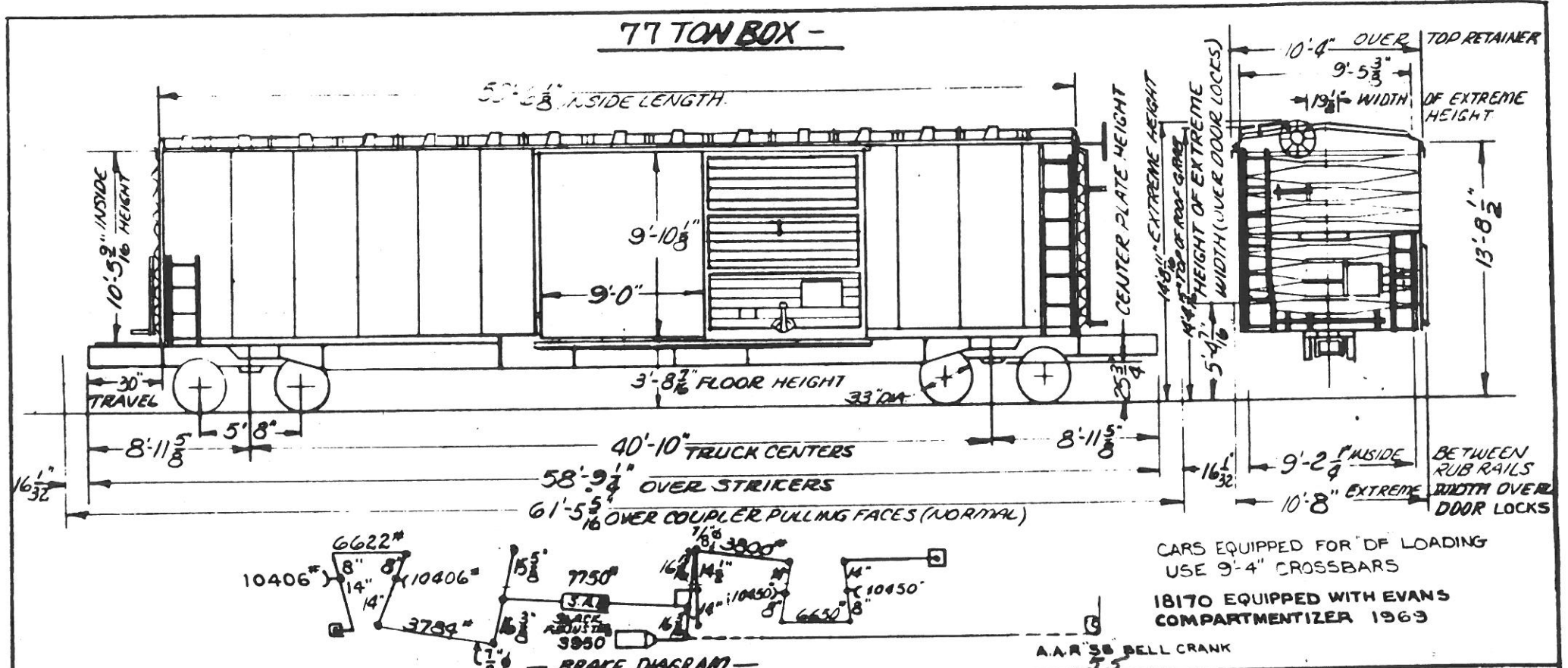

CARS EQUIPPED FOR "DF" LOADING
USE 9'-4" CROSSBARS
18170 EQUIPPED WITH EVANS
COMPARTMENTIZER 1963

- GENERAL -		- BRACE DIAGRAM -	
BUILDER: AMERICAN CAR & FOUNDRY (ST. LOUIS)	CUSHIONING DEVICE: ACF FREIGHT-SAVER	BRAKE BEAM: UNIT NO. 18	
YEAR BUILT: 1964	30" TRAVEL	GENERAL DWG: D.T. & I. DWG. X-6413	
BUILDERS REF: 11-06106	CYLINDER RELEASE VALVE: WESTINGHOUSE "GRB"	JOURNAL: 6" X 11" (FLAT BACK BEARINGS)	
AAR CLASS: XP	DOORS AND FIXTURES: YOUNGSTOWN - TYPE 47	SIDE BEARINGS: STUCKI 656-C	
NO. BUILT: 150	DRAFT GEAR: 50'S MINERA-22-XL, 50'S CARD-WEST. NY-11-F	SIDE FRAME: ASF PATTERN NO. 21930 M. WITH	
CAPY: 4850 CU. FT.	DRAFT GEAR ATTACHMENT: GRADE B C.S. YOKE (B-Y45)	WASTE RETAINER RIBS, INTEGRAL BOX	
AVE. LT. WT.: 63,100 LBS.	ENDS: STD. RY. EQUIP.: TOP SHEET 3/16" BOTTOM SHEET 1/4"	AAR CODE F7S-04BB-UA	
AVE. LOAD LIMIT: 156,900 LBS.	END SILL: 6" X 3 1/2" X 3/16" ANGLE	AAR IDENT. NO. 904, D.T. & I. DWG. W-5959	
- BODY -		SPRINGS: 3 1/16" TRAVEL AAR D-4	
AIR BRAKE MFG: WESTINGHOUSE	FLOOR: 2 3/8" DWELDC (ACROSS CAR)	TRUCK LT.: 8560 LBS.	
AIR BRAKE SCHEDULE: AB1012 WITH ABC-1 VALVE	GENERAL DWG:	TYPE OF TRUCK: 70 TON BARBER S-2-B	
BODY CENTER PLATE: 13 3/4" C.S. WAUGH CG-3808	HAND BRAKE: A-JAX-CONSOLIDATED (14665-D)	STABILIZED, SPRING PLANKLESS	
BODY SIDE BEARING: ROLLED SECTION HEAT TREATED	LINING: END- 3/4" PLYWOOD	EQUIP. FOR UNIT BRAKE BEAM	
CENTER SILL: SLIDING 2 HCS 41.2" X 1/2" ROLLED ZEE SECT.	SIDE: NONE	WHEELS: 33" I WEAR CAST STEEL CU-39	
STATIONARY: 5/16" PRESSED PLATE	ROOF: STD. RY. EQUIPMENT-DIAGONAL PANEL-18 GAUGE	FOR RAISED WHEEL SEAT AXLES	
CENTER SILL AREA: SLIDING 24.24 SQ. IN.	SIDE SILL: 8" X 6" X 3/16" ANGLE	CARS: 18100-18249	
COUPLER: A.A.R. B-E4942B-HT TYPE "E" HEAD,	SIDE BEARING CENTERS: 4'-2"	D.T. & I.	
VERTICAL ANGLE COCK LUG, TYPE "F"	SIDE PLATE: ROLLED 2" X 9 3/4" FT. U.S. STEEL SECT 5-281	MOTIVE POWER DEPT 6-12-64	
SHANK, 43"-PULLING LINE TO PIN	SIDE SHEATHING: .01" COPPER BEARING STEEL	- REVISION -	
COUPLER RELEASE RIGGING: STD. RY. EQUIP. CO. (D.T. & I. DWG. V-1088)	- TRUCK -		
CROSS OVER STEPS: APEX TYPE A-1100 (D.T. & I. DWG. V-6940)	BOULSTER: ASF PATTERN NO 21792-81	2/6/55	3/7/64
	D.T. & I. DWG. W-6408 AAR IDENT NO 1792		
	AAR CODE B7S-04BN-BA		

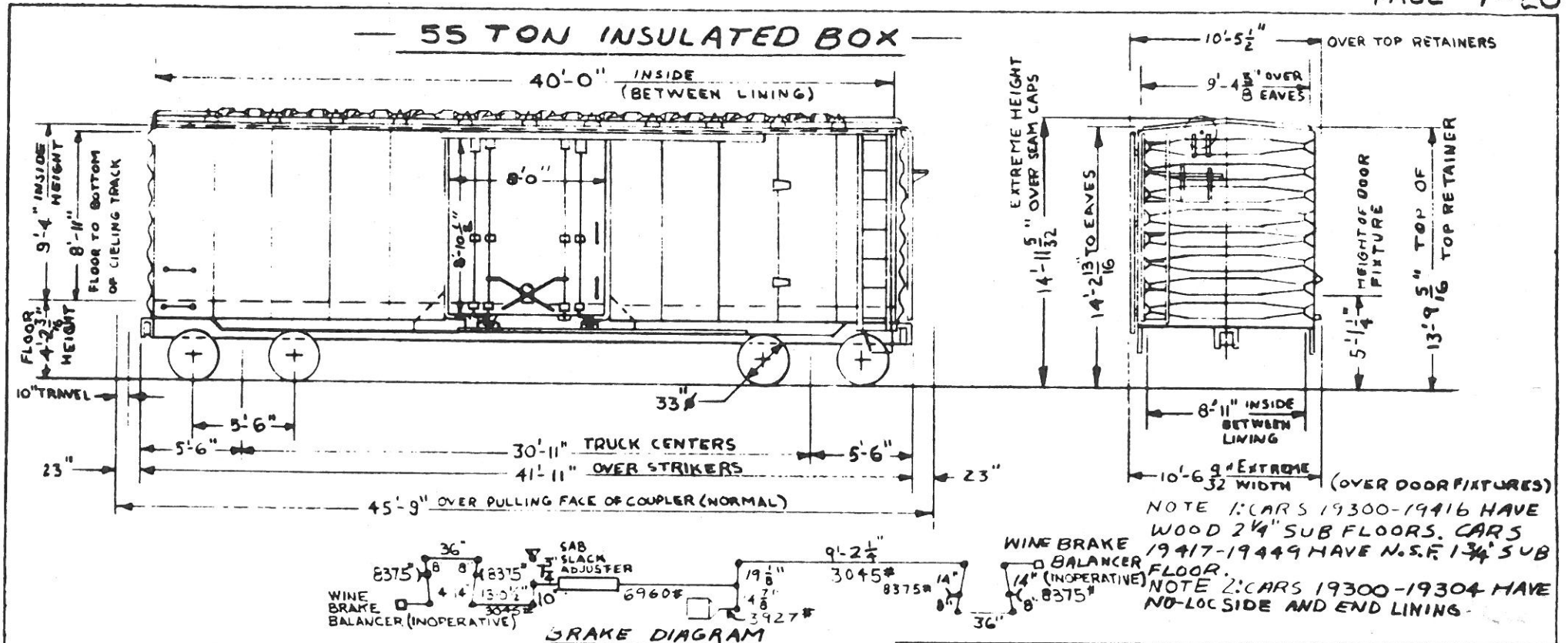

- GENERAL -		LESSOR	NAT'L. EQUIP. LEASING	LEASE: 4210	TERM: 1-21-82
BUILT BY: GREENVILLE STEEL CAR CO.	END: STANRAY SE-8070-C (DWG. V-4725)	JOURNAL: 5 1/2" X 10" ROLLER BEARINGS			
YEAR BUILT: 1950	END SILL: 6" X 3 1/2" X 5 1/16" ANGLE	JOURNAL BEARINGS: BRENCO. 5-A			
INSULATED 1959 BY DT&I	FLOOR: SUB: (SEE NOTE 1)	JOURNAL BEARING STOPBLOCK: PORTEC K-115444			
BUILDERS REF. O.O. 344	MAIN: 2 1/4" DOWELOC	SIDE BEARING: "STUCK" 656-C (DWG. Y-1470)			
AAR CLASS: XLI	GENERAL DWG: V-4577	SIDE FRAME: (ORIGINAL) O.S.F. 5-F23-3			
NO. INSULATED: 150, NO. REWORKED: 100 - 1969	HAND BRAKE: AJAX CONSOLIDATED	(REPAIRS) PAR. CODE FSA-02AF-UA ASF PAT.			
CAPY: 3060 CU. FT.	INSULATION: GUSTIN-BACON "ULTRALITE" #75	NO. 21728-1 DT: 1 DWG. W-3444 INTEGRAL BOX			
AVE. LT. WT.: 66,400 LBS.	4" THICK FIBER-GLASS 3/4" / CU. FT.	MODIFIED FOR ROLLER BEARING PER DWG. W-9547			
AVE. LOAD LIMIT: 110,600 LBS.	LINING: END: 15 1/16" X 5 1/16" X 10'-0" T&G CM FIR	SPRINGS: D-5 10 OUTER, 10 INNER / TRUCK			
	SIDE: 23 3/32" X 3 1/4" X 16'-0" T&G CM FIR	TYPE OF TRUCK: 50 TON A-3 RIDE CONTROL			
	CEILING: 1/2" PLYWOOD	SPRING PLANKLESS: EQUIP FOR UNIT BRAKE BEAMS			
- BODY -	ROOF: STANRAY 7R-8051-C (DWG. V-3542)	MODIFIED FOR ROLLER BEARINGS			
AIR BRAKES MFG: NYAB.CO.	SIDE SILL: 6" X 4" X 3/8" L 6" LEG HORIZ.	WHEELS: 2 WEAR CAST STEEL CM-33			
AIR BRAKE SCHEDULE: AB 10 X 12	SIDE SILL REINFORCEMENT: 6" SHIP CHANNEL, 15.3# / FT.				
BODY CENTER PLATE: 1 1/4" Ø CAST INTEGRAL WITH BOLSTER	SIDE BEARING CENTERS: 4'-2"				
CENTER SILL: (2) Z-26 (AAR) 36.2 lb. / FT.	SIDE PLATE: 7 1/16" @ 9.9# / FT. "W" SECTION	CARS: 19300-19449 (AIR PAK)			
CENTER SILL AREA: 21.3 SQ. IN.	SHEATHING: 0.10" STEEL SHEETS, RIVETED				
COMPARTMENTIZER: EVANS DUAL AIR PAK DB-201410	- TRUCK -	DT&I			
COUPLER: B-E 60A BOTTOM OPERATED	BOLSTER: ORIGINAL - O.S.F. PAT. # 5-B4-3				
COUPLER RELEASE RIG: STANRAY IU-22736-A (DWG. X-9628)	BOLSTER: (REPAIRS) AAR CODE BSA-03DN-BW. BSC PAT.	MECHANICAL ENGINEERING DEPT. 12-5-69			
CUSHIONING DEVICE: KEYSTONE-EC-10-R, 10" TRAVEL	B-5249 OR ASF PAT. 21565-CM D.T. & I				
DOOR: "SUPERIOR" 19542- (DWG. V-4632)	DWG. W-1461 OR W-2486	- REVISIONS -			
DOOR FRAMING: J.T. RYERSON & SON (DWG. V-4595)	BRAKE BEAM: AAR #18-UNIT				
DOOR GASKET: LANDIS IND. CO. DG-104	GENERAL DWG: W-2487				

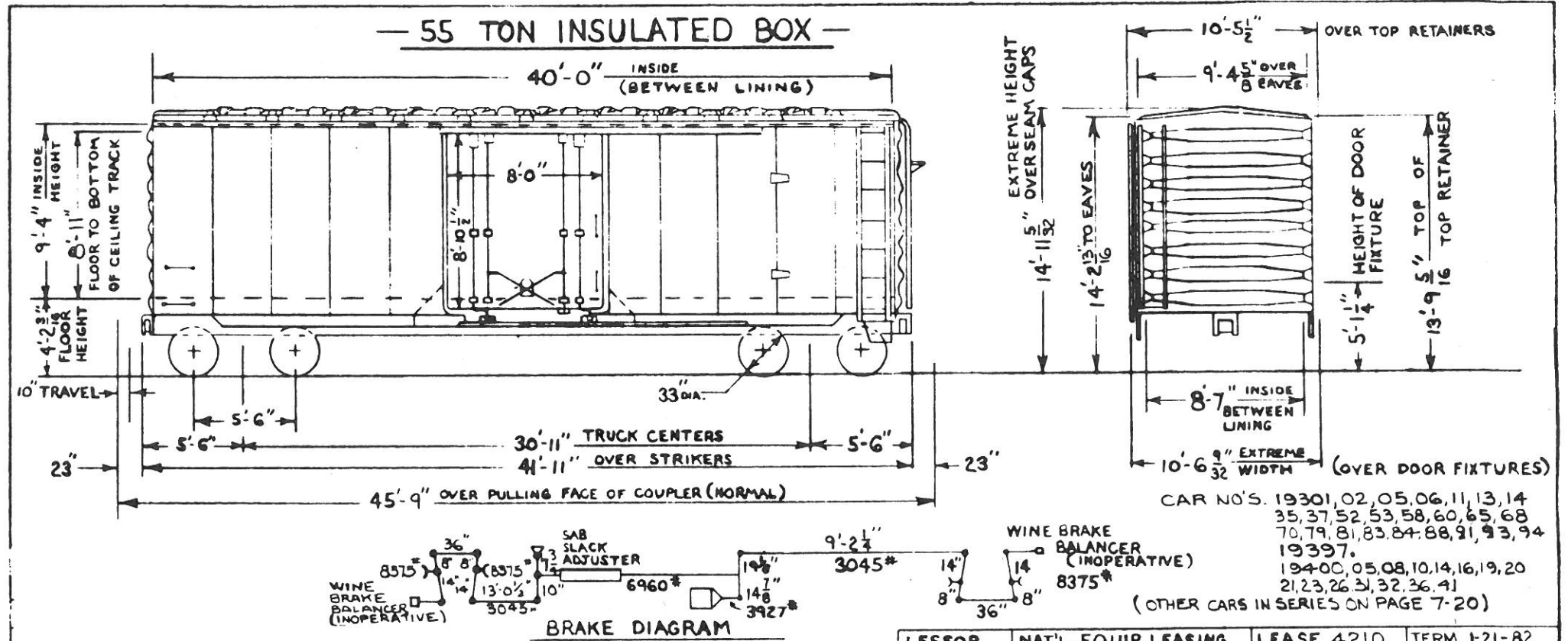

		LESSOR	NAT'L. EQUIP. LEASING	LEASE 4210	TERM 1-21-82
— GENERAL —		END: STANRAY SE-8070-C (DWG V-4725)		JOURNAL: 5 1/2" X 10" ROLLER BEARINGS	
BUILDER: GREENVILLE STEEL CAR CO.		END SILL: 6" X 3 1/2" X 5/8" ANGLE		JOURNAL BEARINGS: BRENCO 5-A	
YEAR BUILT: 1950		FLOOR: SUB 2 1/4" WOOD (19301-19416) 1 3/4" NSF (19419-19441)		JOURNAL BEARING STOP BLOCK: PORTEC K-115444	
INSULATED 1959 BY D.T.&I.		MAIN 2 1/4" DOWEL OC		SIDE BEARING: "STUCKI" 656-C (DWG Y-1470)	
BUILDERS REF: O.O. 344		GENERAL DWG:		SIDE FRAME: (ORIGINAL) O.S.F. 5-F23-3	
A.A.R. CLASS: XLI		HAND BRAKE: AJAX CONSOLIDATED		(REPAIRS) A.A.R. CODE FSA-02AF-UA, ASF PATT. NO. 21728-1 D.T.&I DWG. W-3444 (INTEGRAL BOX)	
NO. INSULATED: 150, NO. REWORKED: 40 - 1969-70		INSULATION: GUSTIN-BACON "ULTRALITE" #75		MODIFIED FOR ROLLER BEARINGS PER DWG. W-9547	
CAPY: 2947 CU. FT.		4" THICK FIBER-GLASS 3/4" FT.		SPRINGS: O-5 10 OUTER, 10 INNER / TRUCK	
AVE. LT. WT:		LINING: END: 5/16" X 5 1/16" X 10'-0" T&G CM FIR		TYPE OF TRUCK: 50TON A-3 RIDE CONTROL	
AVE. LOAD LIMIT:		SIDE: 25/32" X 3 1/4" X 16'-0" T&G CM FIR		SPRING PLANKLESS: EQUIP FOR UNIT BRAKE BEAMS	
— BODY —		CEILING: 1/2" PLYWOOD		MODIFIED FOR ROLLER BEARINGS	
AIR BRAKE MFG.: NYAB CO.		ROOF: STANRAY 7R-8051-C (DWG. V-3542)		WHEELS: 2 WEAR CAST STEEL CM-39	
AIR BRAKE SCHEDULE: AB 10x12		SIDE SILL: 6" X 4" X 3/8" ANGLE 6" LEG HORIZ.			
BODY CENTER PLATE: 11 3/4" CAST INTEGRAL WITH BOLSTER		SIDE SILL REINFORCEMENT: 8" SHIPCHANNEL 15.3 3/4" FT.			
CENTER SILL: (2) Z-26 (AAR) 36.2 3/4" FT.		SIDE PLATE: 7 1/8" @ 9.9 3/4" FT. "W" SECTION			
CENTER SILL AREA: 21.3 SQ. IN.		SHEATHING: 0.10" STEEL SHEETS, RIVETED			
COMPARTMENTIZER: EVANS "DFB" DB-201416		— TRUCK —		CARS: 19300-19449 (DFB)	
COUPLER: B-E 60A BOTTOM OPERATED		BOLSTER: ORIGINAL - O.S.F. PAT. NO. 5-84-3			
COUPLER RELEASE RIG: STANRAY IV-22336-A (DWG. X-9628)		BOLSTER: (REPAIRS) A.A. CODE 85A-03DN-BN, BSC			
CUSHIONING DEVICE: KEYSTONE EC-10-R 10" TRAVEL		PATT. B-5249 OR A.S.F. PATT. 21565-CM D.T.&I.			
DOOR: "SUPERIOR" 11892 - (DWG. V-4632)		DWGS. W-1461 OR W-2486			
DOOR FRAMING: J.T. RYERSON & SON (DWG. V-4595)		BRAKE BEAM: A.A.R. #18-UNIT		D.T.&I. MECHANICAL ENGINEERING DEPT. 4-29-70	
DOOR GASKET: LANDIS IND. CO. D6-104		GENERAL DWG: W-2487			
— REVISIONS —					

— 55 TON INSULATED BOX —

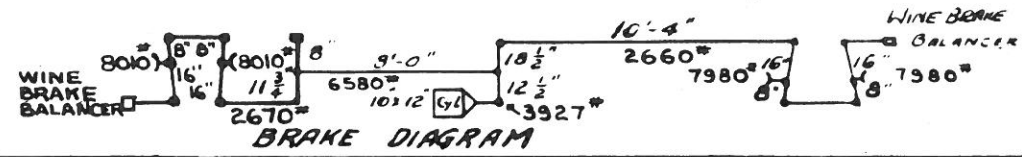
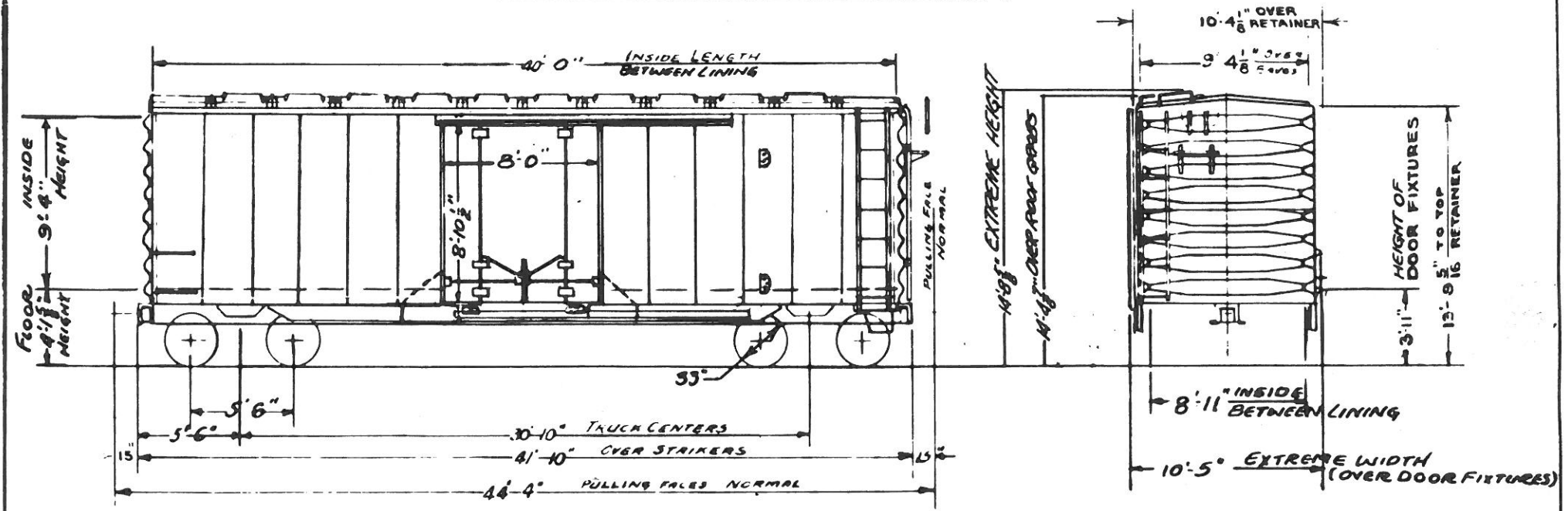

~ GENERAL ~		~ TRUCKS ~
BUILDER: - AMERICAN CAR & FOUNDRY	DRAFT GEAR W.H. MINER AR2-XB, AR2-XL, CARDWELL WESTINGHOUSE N.Y.-11-F	BOLSTER: ORIGINAL O.S.F. PATT. NO. 4957
YEAR BUILT: - 1948	DRAFT GEAR ATTACHMENT: YOKE: C.S. VERT NAT'L MAR	LATEST - BUCKEYE PATT. B-5353
INSULATED 1959 BY D.T. & I	ENDS: AMERICAN CAR & FOUNDRY, D.T. & I, D.W.G. W. 4822	BRAKE BEAM: A.A.R. #18 - UNIT
BUILDERS REF - 3224	END SILL: 6" X 3 1/2" X 5 1/2" ANGLE	GENERAL DWG ACF 31-17663 D.T. & I DWG. W 4820
A.A.R. CLASS: - XL1	FLOOR: SUB. 1 3/4" X 5 1/2" OR 7" T&G.	JOURNAL: 5 1/2" X 10" BOX INTEGRAL
NO. INSULATED: - 100	MAIN: 2 1/2" X 7 1/4" T&G.	SIDE BEARING: STUCKI - 656
CAPY: 3328 CU. FT.	FLOOR, PROTECTION PLATE: 3/16" U.S. STEEL	SIDE FRAME: B.S.C. PATT. F-5126 OR
AVE. LT. WT. 55,000 LBS (")	SEC. 5-300 SAFETY FLOOR PLATE 8 7/8" / 58 FT.	O.S.F. PATT. B236 (OBSOLETE)
AVE. LOAD LIMIT: 122,000 LBS (")	GENERAL DWG: V-5234 (INT) - V-2455 (ORIG. AR2)	WITH WASTE RETAINER RBS. A.A.R. IDENT # 38
	HAND BRAKE "UNIVERSAL" WX-2000	SPRINGS COIL ELLIPTIC 1 1/16" TRAVEL
	INSULATION: GUSTIN-BACON "ULTRALITE" #75	TYPE OF TRUCK: 50 TON COIL-ELLIPTIC SPRINGS, SPONGE
~ BODY ~	4" THICK FIBER-GLASS, 3/4" / CU. FT.	FLAMELESS EQUIP FOR UNIT BRAKE BEAMS.
AIR BRAKE MFG.: N.Y. A.B. CO.	LINING: END 1 5/8" X 5 1/8" T&G.	CARS: 19369
AIR BRAKE SCHEDULE: A.B. 10" X 12"	SIDE 2 3/8" X 3 3/8" T&G.	D.T. & I
BODY CENTER PLATE: - DROP FORGED	CEILING - 1/2" PLYWOOD	MOTIVE POWER DEPT 2-29-60
BODY SIDE BEARING: CARBON STEEL	ROOF: "MURPHY" STRAIGHT OR DIAGONAL PANEL	REVISIONS
CENTER SILL: A.A.R. Z-26; 2; 72.4 LB/FT.	SIDE SILLS: 6" X 3 3/4" X 9 1/2" ANGLE	12/60 5-62 7-63 2/65 3/70 3/74 8/74
CENTER SILL AREA: 21.3 SQ IN	SIDE SILL REINFORCEMENT: 8" @ 21A #17 CHANNEL	
COUPLER: TYPE "E" 6 1/4" X 8" BOT. OPERATED	SIDE BEARING CENTERS 4'-2"	
COUPLER RELEASE RIG: IMPERIAL ROTARY	SIDE PLATE: 7 1/8" @ 99 #7 FT "W" SECTION	
DOOR: "YOUNGSTOWN" 9190, D.T. & I, D.W.G. VATH	SHEATHING: 0.10 STEEL - WELDED	
DOOR FRAMING: YOUNGSTOWN STEEL DOOR CO.		
DOOR GASKET: YOUNGSTOWN B660		

85 CARS EQUIPPED WITH
PULLMAN COMPARTMENTIZERS
1963 (D.T.&I DWG. V-6380)

55 TON INSULATED BOX

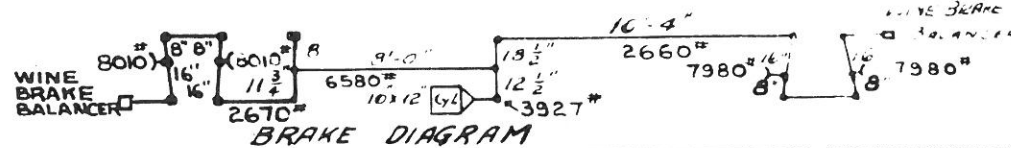
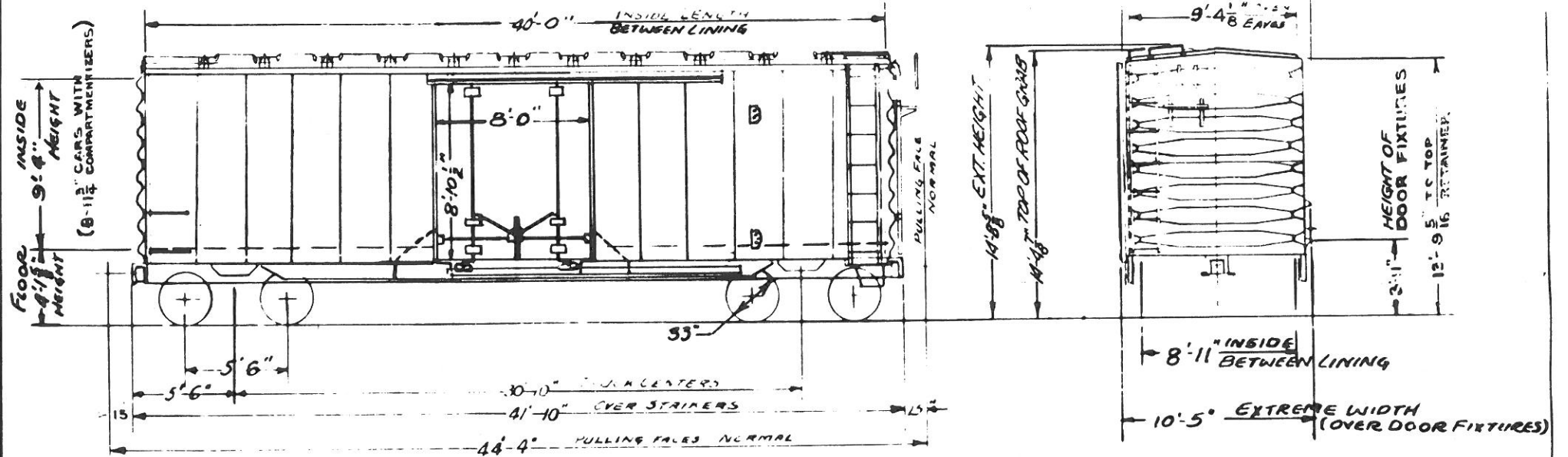

NOTE 2: 19634 EQUIP.
WITH NATIONAL "3-C" CUSHION
UNDERFRAME - 24" TRAVEL

~ GENERAL ~		~ TRUCKS ~	
BUILDER: - AMERICAN CAR & FOUNDRY	DRAFT GEAR W.H. MINER A22-XB, A22-XL, CARDWELL WESTINGHOUSE NY-11-F	BOLSTER: ORIGINAL O.S.F. PATT. NO. 4957	LATEST - BUCKEYE PATT. B-5353
YEAR BUILT: - 1948 AND 1949	ENDS: AMERICAN CAR & FOUNDRY, D.T.I. DWG. W-4420	BRAKE BEAM: A.A.R. #18 - UNIT	
INSULATED 1959 BY D.T.&I	ENDSILL: 6" X 3 1/2" X 5 1/4" ANGLE	GENERAL DWG. A.C.F. 31-17663 D.T.&I DWG. W-4870	JOURNAL: 5 1/2 X 10" BOX INTEGRAL
BUILDERS REF - 3224 OR 3338	FLOOR: SUB. 1 3/4" X 3 OR 7" T&G	SIDE BEARING: STUCKI - 1656	SIDE FRAME: 95' PATT. F-5126 OR O.S.F. PATT. B2316 (OBSOLETE)
A.R. CLASS: - XLI OR XMI	MAIN: 2 1/4 X 1 1/4 T&G	WITH WASTE RETAINER RIAS. A.A.R. IDENT #38	SPRINGS COIL ELLIPTIC 1 1/4" TRAVEL
NO. INSULATED: - 100	FLOOR PROTECTION PLATE: 3/16" U.S. STEEL	TYPE OF TRUCK 50 TON COIL-ELLIPTIC SPRING, SPRING	PLANKLESS EQUIP FOR UNIT BRAKE BEAMS
CAPV: 3328 CU. FT. (3142 CU. FT. COMP. PER)	SEC. 5-300 SAFETY FLOOR PLATE 8 7/8" SQ. FT.	CARS: 19550-19649	
AVE. LT. WT. 59,400 LBS ()	GENERAL DWG: V-5259 (INT) - V-2455 (ORIG. A.R. 60)	D.T.&I	
AVE. LOAD LIMIT: 7,600 LBS ()	HAND BRAKE "UNIVERSAL" WX-2000	MOTIVE POWER DEPT 2-29-60	
	INSULATION: GUSTIN-BACON "ULTRALITE" #75	REVISIONS	
~ BODY ~	4" THICK FIBER-GLASS 3/4" CUFT	12/60 5-62 7-63 2/65 5/70 3/74	
AIR BRAKE MFG: NY. A.B. CO.	LINING: END 1 5/16" X 5 1/16" T&G		
AIR BRAKE SCHEDULE: AB 10" X 12"	SIDE 2 3/32" X 3 1/8" T&G		
BODY CENTER PLATE: - DROP FORGED	CEILING - 1/2" PLYWOOD		
BODY SIDE BEARING: CARBON STEEL	ROOF: "MURPHY" STRAIGHT OR DIAGONAL PANEL		
CENTER SILL: A.A.R. Z-26; 2; 72.4 LB/FT.			
CENTER SILL AREA 21.3 SQ IN	SIDE SILLS: 6" X 3 1/2" X 5 1/4" ANGLE		
COUPLER: TYPE "E" 6 1/2" X 8" BOT. OPERATED	SIDE SILL REINFORCEMENT: 8" @ 21A 7/8" FT CHANNEL		
COUPLER RELEASE RIG: IMPERIAL ROTARY	SIDE BEARING CENTERS 4'-2"		
DOOR: "YOUNGSTOWN" 9190, D.T.I. DWG. V474	SIDE PLATE: 7 1/4" @ 99 7/8" FT "W" SECTION		
DOOR FRAMING: YOUNGSTOWN STEEL DOOR CO.	SHEATHING: 010 STEEL - WELDED		
DOOR GASKET: YOUNGSTOWN B660			

— 55 TON INSULATED BOX —

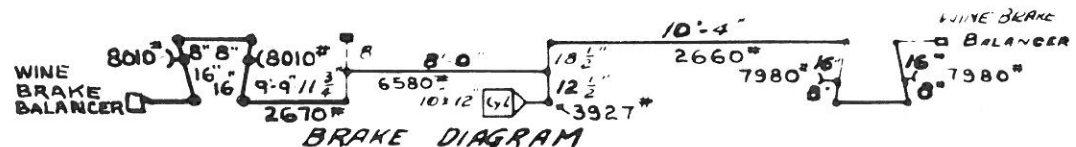
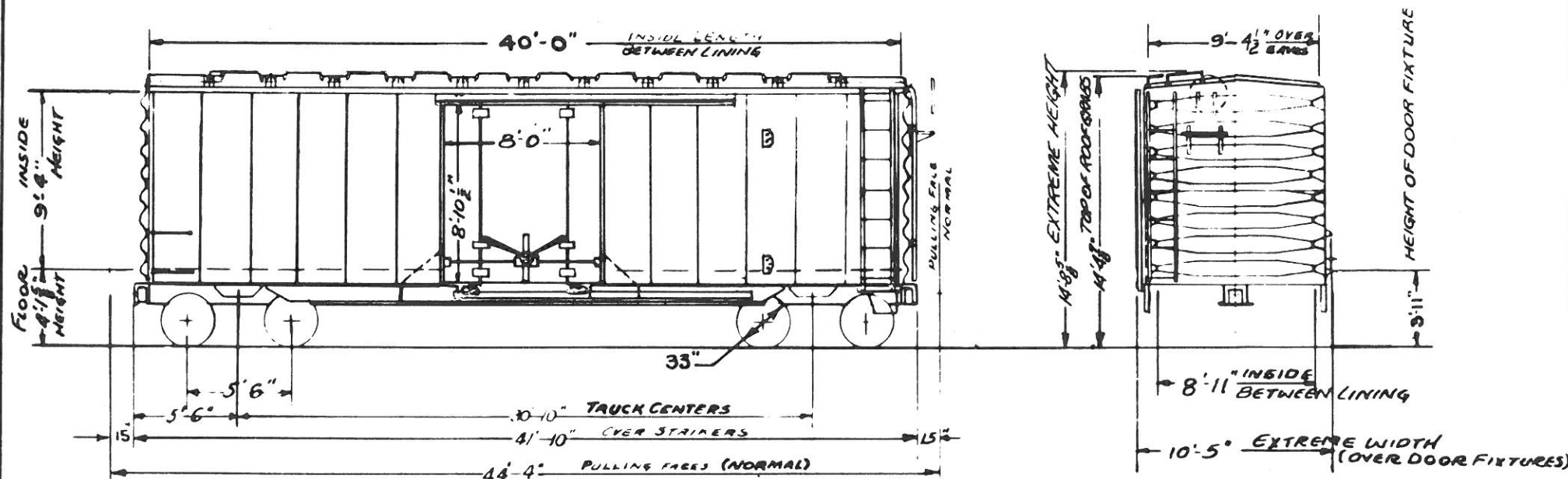

~ GENERAL ~		~ TRUCKS ~	
BUILDER: - AMERICAN CAR & FOUNDRY	DRAFT GEAR W/H MINER A22-XB, A22-XL, GARDNELL WESTINGHOUSE NY-11-F	BOLSTER: ORIGINAL O.S.F. PATT. NO. 4957	REPLACEMENT: BSC PATT. NO. B-5353
YEAR BUILT: - 1948 AND 1949	DRAFT GEAR ATTACHMENT: YOKE: C.S. VERT. MATH	BRAKE BEAM: A.A.R. #18-UNIT	
INSULATED 1961 BY D.T. & I.	ENDS: AMERICAN CAR & FOUNDRY	GENERAL DWG ACF 31-17663 D.T. & I. DWG W-4820	
BUILDERS REF - 3224 OR 3338	END SILL: 6" X 3 1/2" X 5 1/4" ANGLE	JOURNAL: 5 1/2" X 10" BOX INTEGRAL	
A.A.R. CLASS: - XL1	FLOOR: SUB. 1 3/4" X 7 OR 7" T&G	SIDE BEARING: STUCKI: 656-C	
NO. INSULATED: - 25	MAIN: 2" X 1 1/2" DOWELOC (BEECH) (APPLIED LONGITUDINALLY)	SIDE FRAME: ORIGINAL, OSF PATT. B236	
CAPY: 3328 CU. FT.	BULKHEADS, HINGED, MOVABLE - SHUNK MFG.	REPLACEMENT, BSC PATT. F-5126	
AVE. LT. WT. 55,100 LBS	GENERAL DWG: V-5413	WITH WASTE RETAINER RBS. A.A.R. IDENT. NO. 38	
AVE. LOAD LIMIT: 121,900 LBS	HAND BRAKE "UNIVERSAL" WX-2000	SPRINGS: COIL ELLIPTIC 1 1/16" TRAVEL	
~ BODY ~		TYPE OF TRUCK: 50 TON COIL-ELLIPTIC SPRING, SPRING PLANLESS, EQUIP. FOR UNIT BRAKE BEAMS.	
AIR BRAKE MFG.: NY. A.B. CO.	INSULATION: GUSTIN-BACON "ULTRALITE" #75	CARS: 19650 - 19674	
AIR BRAKE SCHEDULE: A.B. 10" X 12"	4" THICK FIBER-GLASS 3/4" CU. FT.	D. T. & I.	
BODY CENTER PLATE: - DROP FORGED	LINING: END 1 1/8" X 25 1/16" NULOC PANEL		
BODY SIDE BEARING: CARBON STEEL	SIDE 25 1/32" X VARIOUS, NULOC PANEL	MOTIVE POWER DEPT 5-29-61	
CENTER SILL: A.A.R. Z-26; 2; 72.4 LB/FT.	CEILING - 1/2" PLYWOOD	REVISIONS	
CENTER SILL AREA 21.350 IN	ROOF: "MURPHY" STRAIGHT OR DIAGONAL PANEL	7-63 2/65 6/70 3/74	
COUPLER: TYPE "E" 6 1/4" X 8" BOT. OPERATED	SIDE SILLS: 6" X 3 1/2" X 5 1/4" ANGLE	FAM	
COUPLER RELEASE RIG: IMPERIAL ROTARY	SIDE SILL REINFORCEMENT: 8" @ R1.4 "/FT CHANNEL		
DOOR: "YOUNGSTOWN" 9190-E, DWG V-5309	SIDE BEARING CENTERS: 4'-2"		
DOOR FRAMING: YOUNGSTOWN STEEL DOOR CO.	SIDE PLATE: 7 1/4" @ 99 "/FT "W" SECTION		
DOOR GASKET: YOUNGSTOWN 8660	SHEATHING: 0.10 STEEL - WELDED		

— 55 TON INSULATED BOX —

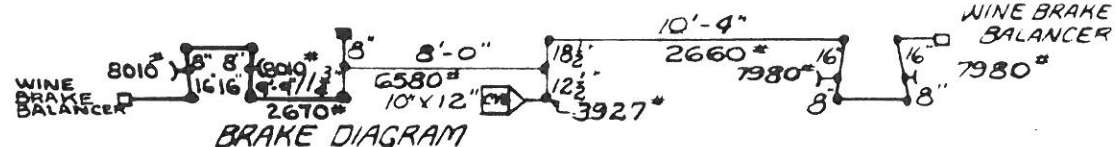
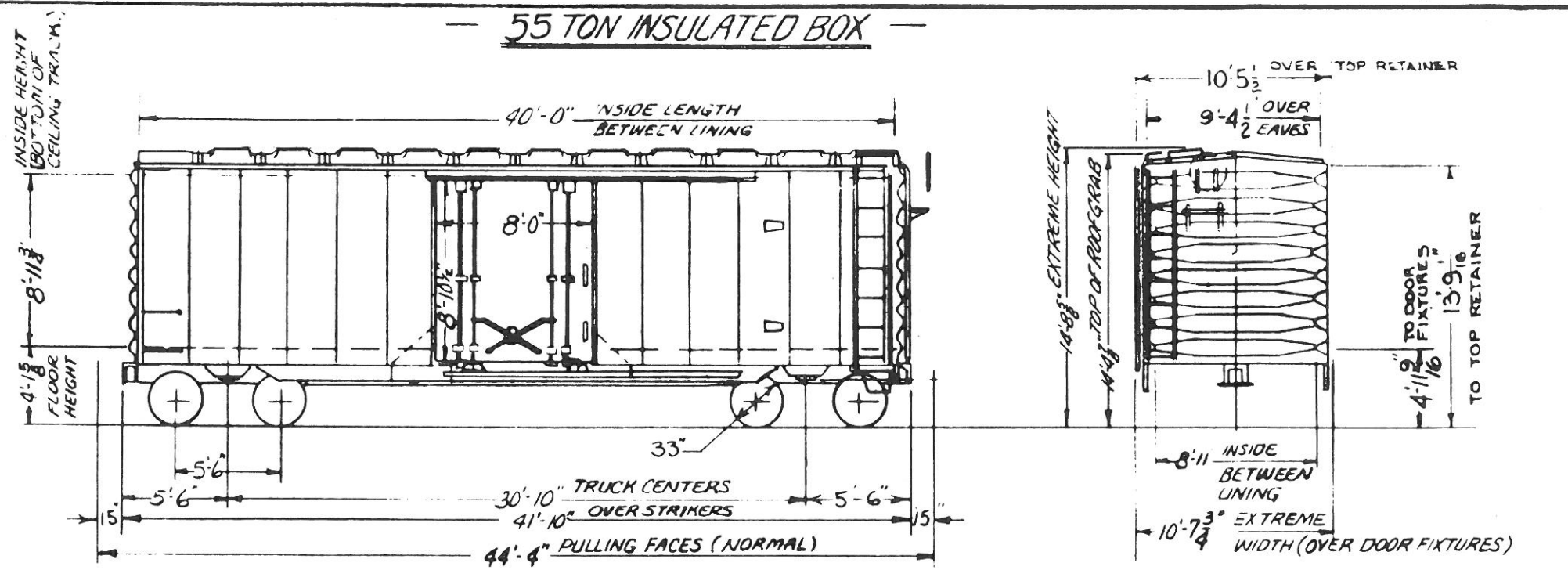

— GENERAL —		— TRUCKS —	
BUILDER: AMERICAN CAR AND FOUNDRY	DRAFT GEAR: W. N. MINER A22-XB A22-XL CARDWELL WESTINGHOUSE NY-11-F	BOLSTER: ORIGINAL OSF PATT. NO. 4957	
YEAR BUILT: -1948 AND 1949	DRAFT GEAR ATTACHMENT, YOKE: C.S. VERT. (Y-40)	REPLACEMENT: BSC PATT. NO. B-5353	
INSULATED 1963 BY D.T. & I.	ENDS: AMERICAN CAR AND FOUNDRY	BRAKE BEAM: A.A.R. #18 UNIT	
BUILDERS REF. 3224 OR 3338	END SILL: 6" X 3 1/2" X 5/16" ANGLE	GENERAL DWG. A.C.F. 31-17663 D.T. & I. DWG. W-4820	
A.A.R. CLASS: -XLI	FLOOR: SUB. 1 3/4" X 5/8" 7" T&G.	JOURNAL: 5/12" X 10" BOX INTEGRAL	
NO. INSULATED: 14	MAIN 2" X 12" DOW LOC (APPLIED LONGITUDINALLY)	SIDE BEARING: STUCKI. 656-C	
CAPY. 3142 CU. FT.	GENERAL DWG: V-5413	SIDE FRAME: ORIGINAL OSF PATT. 8236	
AVE LT WT. 59,600	HAND BRAKE "UNIVERSAL" WX-2000	REPLACEMENT BSC PATT F-5126	
AVE LOAD LIMIT 117,900	INSULATION: GUSTIN-BACON "ULTRALITE" #75	WITH WASTE RETAINER RIBS A.A.R. IDENT NO. 38	
- BODY -	4" THICK FIBER-GLASS 3/4" / CU. FT.	SPRINGS 2 1/2" TRAVEL	
AIR BRAKE MFG.: N.Y. A. B. CO.	LINING: END 1 1/2" X 25 1/16" NULOC PANEL	TYPE OF TRUCK: 50 TON, CUSHION RIDE PKG. UNIT.	
AIR BRAKE SCHEDULE: A B. 10" X 12"	SIDE 1 1/2" X VARIOUS NULOC PANEL		
BODY CENTER PLATE: - DROP FORGED 11 3/4"	CEILING - 1/2" PLYWOOD		
BODY SIDE BEARING: - CARBON STEEL	ROOF: "MURPHY" STRAIGHT OR DIAGONAL PANEL		
CENTER SILL: A.A.R. 2-26, 2, 72.4" / FT.		CARS 19700-19713	
CENTER SILL AREA: 21.3 SQ. IN.	SIDE SILL: 6" X 3 1/2" X 5/16" ANGLE	D.T. & I.	
COMPARTMENTIZER: PULLMAN STD. DWG. V-6380	SIDE SILL REINFORCEMENT: 8" @ 21.4" / FT CHANNEL	MOTIVE POWER DEPT 5-27-63	
COUPLER TYPE "E" 6 1/4" X 8" SLOTTED BOT. OPERATED	SIDE BEARING CENTERS: 4'-2"	REVISIONS	
COUPLER RELEASE RIG: IMPERIAL ROTARY	SIDE PLATE: 7 1/16" @ 9.9" / FT W. SECTION	2/65	5/10
DOOR SUPERIOR: 15786-C, D&I DWG. V-6400	SHEATHING: 0.10" STEEL-WELDED	3/24	
DOOR FRAMING: WHITEHEAD HALESON DWG. V-5953			
DOOR GASKET: LANDIS IND CO "DG 104"			

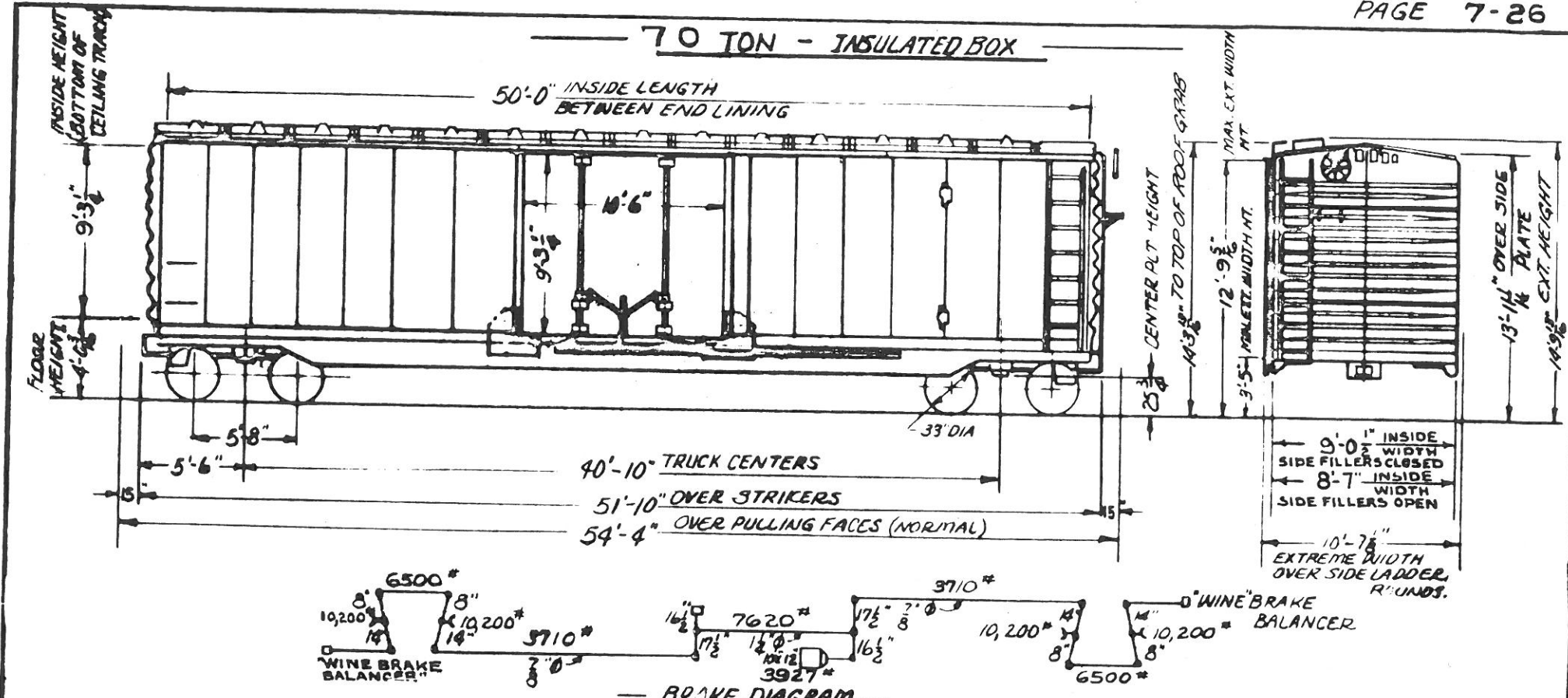

GENERAL		TRUCKS
BUILDER: PULLMAN STANDARD CAR MFG. CO.	DRAFT GEAR - CARDWELD WESTINGHOUSE, NY. IIF OR MINER A-22XL	BOLSTER: B.S.C. PATT. B-7062 DWG. W-3094 (DND)
YEAR BUILT: 1953	DRAFT GEAR ATTACHMENT: GS. YOKE - NAT'L. MALL. (Y-40)	AAR CODE: 87A-01EB-BN (ON CAR)
INSULATED: 1963 + 1964 BY DTAX	ENDS: PULLMAN - TOP SHEET 3/16" BOTTOM SHEET 3/16"	AAR CODE: 87A-03DN-AN (FOR REPLACEMENT)
BUILDERS REF: 8112-4	END SILL: 6" X 3 1/2" X 5 1/16" L	BRAKE BEAMS: #78 UNIT
A.A.R. CLASS: XLI	FLOORING: SUB. 1/2" PL. "DD	CENTER PLATE: INTEGRAL
NO. INSULATED: 30	MAIN, 2 X 12 - DWELOC	GEN'L DWG.: DT #1 W-2935
COPY 4396 CLFT.	(APPLIED LONGITUDINALLY)	JOURNALS: 6" X 11" BOX, INTEGRAL, WITH WASTE RETAINER
AVE LT WT 72,000 LBS	GENERAL DWG:	SIDE BEARINGS: "STUCKI" 650-C
AVE LOAD LIMIT 148,000 LBS	HAND BRAKE: AJAX CONSOLE OR MINER	SIDE FRAMES: ASF PATT #216-55-E DWG. W-3984
BODY		AAR CODE: FTA-02AB-UA
AIR BRAKE MFG. NY. AIR BRAKE CO. AB-10"	INSULATION: GUSTIN-BACON ULTRALITE #75	SPRINGS: 3 1/4" TRAVEL, AAR D-5
AIR BRAKE SCHEDULE: AB 10" X 12"	4" THICK FIBER GLASS 3/4" / CU. FT.	TRUCK WT: 8320
BODY CENTER PLATE: DROP FORGED 19 3/4" DIA	LINING: END 1 1/16" X 2 1/2" NULOC PANEL	TYPE OF TRUCK: 70 TON, 4 BRIDE CONTROL SPRINGS
BODY SIDE BEARING: CARBON STEEL (CARBONITE SEC. M. 9153)	SIDE 2 3/8" X 1 3/4" NULOC PANEL	PLANLESS EQPT. FOR UNIT BRAKE BEAMS
CENTER SILL: 2 Z. 2 1/2 WELDED 36.2 LBS. EA.	CEILING: 1/2" PLYWOOD	WHEELS: 1 NEAR WROUGHT STEEL
CENTER SILL AREA: 21.3 SQ. IN.	ROOF: PULLMAN DWG. W-1982	CARS: 19800-19829
COMPARTMENTIZER: EVANS "DFB" DWG. V-6869	SIDE SILL: 6" X 6" X 1/4" L. RETENERS - 50 LB. CHANNEL	DT. & I
COUPLER: TYPE "E" 6 1/2" X 8" SLOTTED, BOTTOM OR	" BRG. CENTERS: 4'-2"	MOTIVE POWER DEPT.
COUPLER RELEASE RIGGING: "PULLMAN" ROTARY"	SIDE PLATE: ROLLED Z. U.S. STEEL SECTION Z"-281	12-30-63
DOOR: YOUNGSTOWN STEEL DOOR DWG. V-6511	SHEATHING 0.10" RIVETED STEEL	- REVISIONS -
DOOR BRACING: YOUNGSTOWN STEEL DOOR DWG. V-6521	SIDE FILLERS: 19802-EQUIPCO 251-H-15858-A	
DOOR CASSET: YOUNGSTOWN 63-10590 DWG. X-6516	REMAINING CARS: EVANS	
	SF-201077 (D.T.81 DWG W-8029)	

6/10	9/14						
------	------	--	--	--	--	--	--

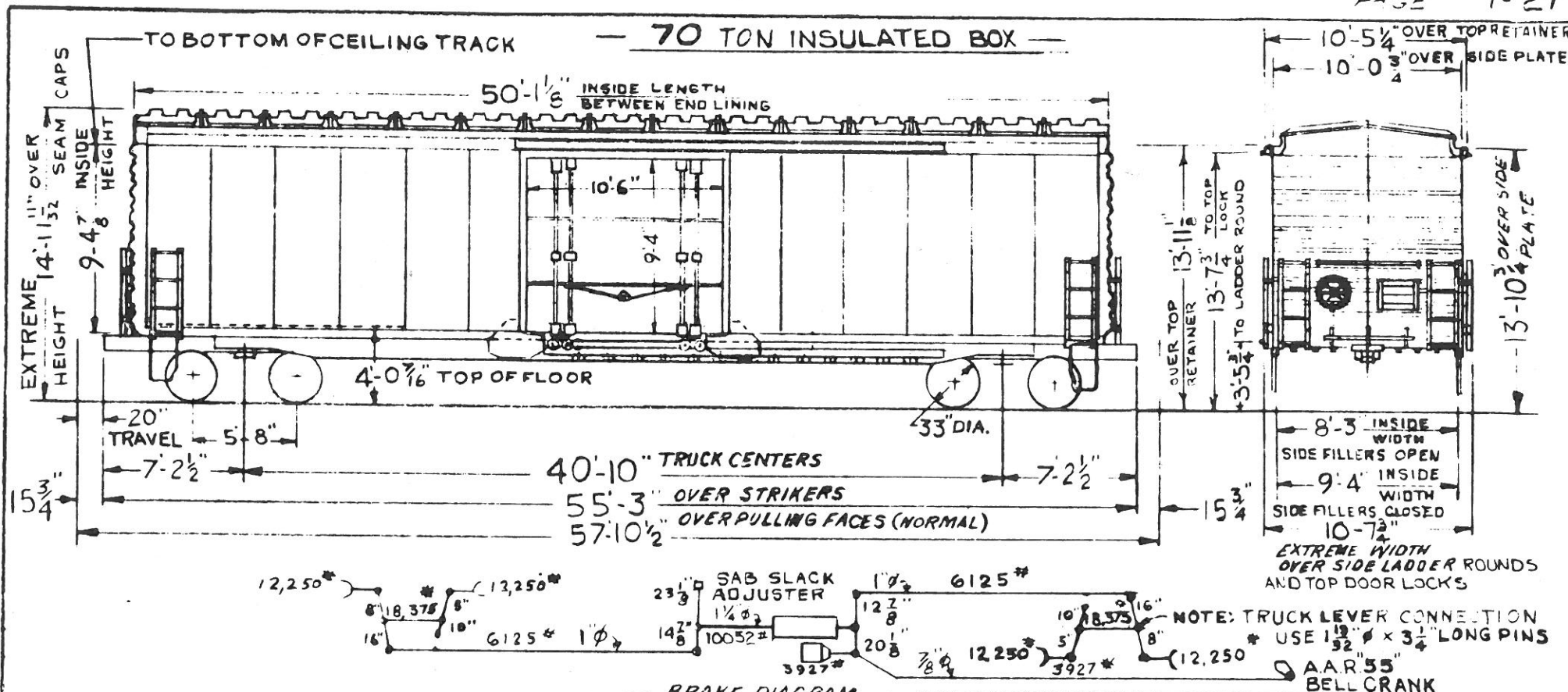

~ GENERAL ~		LESSOR	USRY LEASING CO.	LEASE 4100	TERM 11-477
BUILDER: U.S. RAILWAY EQUIPMENT CO.	CUSHION DEVICE (CON) 20" TRAVEL 70 TON CG-3660-G	BRAKE BEAM: CRECO 15469-1-A *24 (UNIT)			
YEAR BUILT: 1967	DOOR: SUPERIOR 15994 (D.T.#1) (DWG. V-9048)	GENERAL DWG: SYM-WAYNE R-8538 (X-10085)			
BUILDER REF: 1-1016	DOOR GASKET: LANDIS - 212-5	JOURNALS: 6"x11" ROLLER BEARINGS			
A.A.R. CLASS: XLI	DRAFT GEAR: MINER A-22-XL	JOURNAL BEARING: TIMKEN E-21862 6"x11"			
CAPY: 4640 CU. FT.	DRAFT GEAR ATTACHMENT: GRADE B YOKE (BY-40)	SIDE BEARINGS: STUKI 656-C (DWG. Y-1470)			
AVE. LT. WT.: 77,500 LBS.	ENDS: STANRAY SE-20679 TOP SHEET 3/16" BOTTOM SHEET 1/4"	SIDE FRAME: A.A.R. CODE F75-04BN-UA			
AVE. LOAD LIMIT: 142,500 LBS.	END SILLS: 6"x3 1/2"x5/16" ANGLE	SYM-WAYNE PATT. NO. TF-7173-UI (D.T.#1) DWG. W-10086) A.A.R. IDENT. NO.			
~ BODY ~		E.L. BRUCE CO.			
AIR BRAKE MFG.: NEW YORK AIR BRAKE	GENERAL DWG: EVANS PRODUCTS CO. IE-20061-E	SPRINGS: AAR D-5 14 OUTER & 10 INNER			
AIR BRAKE SCHEDULE: AB 1012 (ABD VALVE)	HAND BRAKE: UNION RY EQUIP. D-2375-A	COILS PER TRUCK			
BODY CENTER PLATE: 13 3/4" CAST STEEL	INSULATION: FLOOR: STYRO-FOAM-DOW	TYPE OF TRUCK: 6"x11" BARBER S-2-C			
"A" END WAUGH CG-4101 "B" END WAUGH CG-4100	REMAINDER: TYPT FIBER GLASS	STABILIZED, EQUIPPED FOR ROLLER BEARINGS			
BODY SIDE BEARINGS: FORGED WEDGE SECTION	LINING: 3/4" PLYWOOD	WHEELS: 1 WEAR CAST STEEL - CJ-33			
BODY SIDE BEARINGS: FORGED WEDGE SECTION	ROOF: STANRAY SR-20681-B	CARS: 19900-19924			
CENTER SILL: SLIDING: 2,41.2" FT ROLLED ZEE EX-TEN 50	SIDE SILL: 6"x6"x3/8" ANGLE - EX-TEN 50	D.T.#1.			
STATIONARY: 3/16" PRESSED PLATE - A-36 STEEL	SIDE SILL REINFORCEMENT: 1/16" FABRICATED STL.	MECHANICAL ENG. DEPARTMENT 10-30-69			
CENTER SILL AREA: SLIDING: 24.24 SQ. IN.	SIDE PLATE: STANRAY 7W-19675-A	- REVISION -			
STATIONARY: 12.92 SQ. IN.	SIDE PLATE: STANRAY 7W-19675-A				
COMPARTMENTIZER: EVANS DFB (DWG. V-9418)	BREATHING: @ DOOR 3/16" A-245 STEEL				
COUPLER: BEG 7A-HT-25" SHANK	REMAINDER: 10" A-245 STEEL				
COUPLER RELEASE RIGGING: STANRAY 4U-19749C	~ TRUCK ~				
CROSS OVER STEP: U.S. GYPSUM G2211-P	BOLSTER: AAR CODE B75-08EB BN SYM-WAYNE PATT. NO.				
CUSHIONING DEVICE: HYDRA-CUSHION-TYPE 12	60-7430 (D.T.#1) DWG. W-10087) AAR IDENT. NO.				
	ROLLER BEARING				

- 70 TON INSULATED BOX -

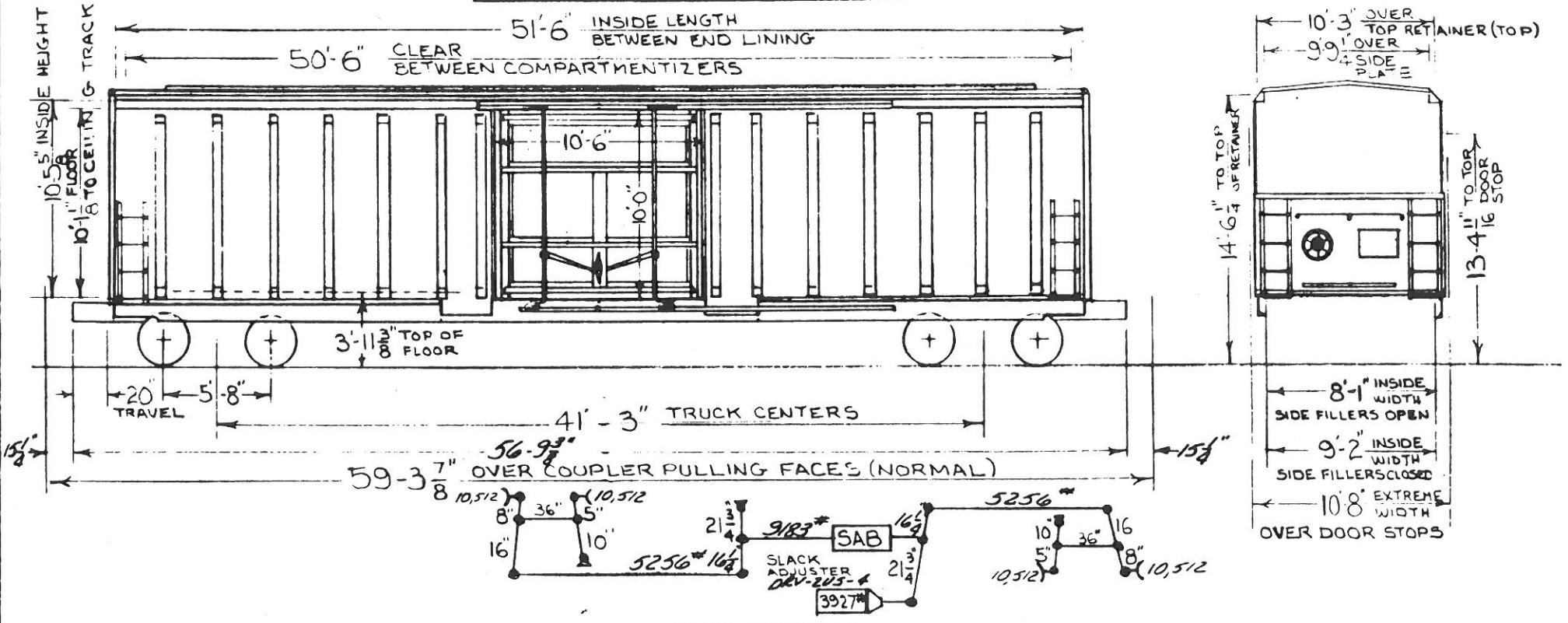

- BRAKE DIAGRAM -

LESSOR		GATX-BOOTHE CORP.	LEASE 4120-1	TERM. 12-27-83
- GENERAL -				
BUILDER: PACIFIC CAR & FOUNDRY	DOOR: YOUNGSTOWN 68-37184-G	BRAKE BEAM: 18 UNIT AD. SMITH #96		
YEAR BUILT: 1968	PLUG TYPE	GENERAL DWG.: N.C.G. 37831-70 (REV. D.T. & I. W-10087)		
BUILDERS REF: 6937	DOOR LINER: PLASTIC-THERM-X DWG. Q2-002	JOURNALS: 6"x11"		
A.A.R. CLASS: XLI	DOOR GASKET: LANDIS D-8165	JOURNAL BEARINGS: BRENCO DWG 2583.5A		
CAPY: 4765 CU. FT.	DRAFT GEAR: MINER A-22-XL	SIDE BEARINGS: STUCKI "656-C (DWG. Y-1470)		
AVE. LT. WT. 79,200 LBS.	DRAFT GEAR ATTACHMENT: C.S. YOKE 8 X40	SIDE FRAME: A.A.R. CODE F75-04BN-UA NATIONAL		
AVE. LOAD LIMIT 140,800 LBS.	ENDS: STANIRAY SE-21427, TOP SHEET 3/4" THK. BOT. SH. 3/16"	CASTINGS PATT. No. 43931-E		
	END SILL: ANGLE 6X3 1/2 X 5 1/8"	(D.T. & I. DWG.) A.A.R. IDENT.		
	FLOORING: SUB 1/4" PLYWOOD	NARROW PEDESTAL		
	MAIN- 2" APITONG MAHOGANY-BETWEEN BOLSTER	SPRINGS: D-5 14 OUTER & 10 INNER COILS /TRUCK		
	2 FIR-BOLSTER TO ENDS	TYPE OF TRUCK: BARBER S-2-C 6"x11"		
- BODY -				
AIR BRAKE MFG.: WESTING HOUSE, GUSTIN-BACON FITTING	GENERAL DWG. P.C. & F. CO. 6937-13	STABILIZED, EQUIPPED FOR UNIT		
AIR BRAKE SCHEDULE: AB1012 (ABD VALVE)	HAND BRAKE: MINER 6600-L 1966	BRAKE BEAMS & ROLLER BEARINGS		
BODY CENTER PLATE:	INSULATION: POLYURETHANE FOAM IN PLACE	WHEELS: 2 WEAR WROT STEEL M-33		
BODY SIDE BEARING: 2 1/4" X 2 3/4" SQ. ASTM A 576 GR	2# 1 CU FT AVE DENSITY			
CENTER SILL SLIDING: 8-20 @ 41.2" FT. TRU-TEN STEEL	LINING: 3/4" PLYWOOD			
STATIONARY: 13" @ 27.3" FT. A-36	ROOF: STANIRAY DWG. SR-21428-A			
CENTER SILL AREA: SLIDING 24.24 SA/IN.	SIDE FILLERS: PRECO W 21519 (6 POSITION)	CARS: 20030-20039		
STATIONARY	SIDE SILL: ANGLE 6X4 X 3/16"			
COMPARTMENTIZER: PRECO MODEL BK-9, NEW DESIGN	SIDE SILL REINFORCEMENT: 13" @ 27.3" FT. CENTER			
COUPLER: B-EGDANT (BOTTOM ORIENTED) ASF	SIDE PLATE: P.C. & F. CO. DWG. R163-276	D.T. & I. RAILROAD		
COUPLER RELEASE RIGGING: STANIRAY 90-17224-X	SHEATHING: .067" HTLA STEEL EXTEN 45			
- TRUCK -				
CROSSOVER STEP: U.S. 6175047 62246-P	BOLSTER: A.A.R. CODE B75-04BN-BN NATIONAL	MECHANICAL ENGINEERING DEPT. 1-29-70		
CUSHIONING DEVICE: HYDRA-CUSHION TYPE 20-14A	CASTINGS PATT. NO. 37831-10 (D.T. & I. DWG.)			
20" TRAVEL	A.A.R. IDENT. NO. ROLLER BEARING	- REVISIONS -		

88 TON BOX

EXTREME WIDTH OVER SIDE LADDERS AND DOOR FIXTURES

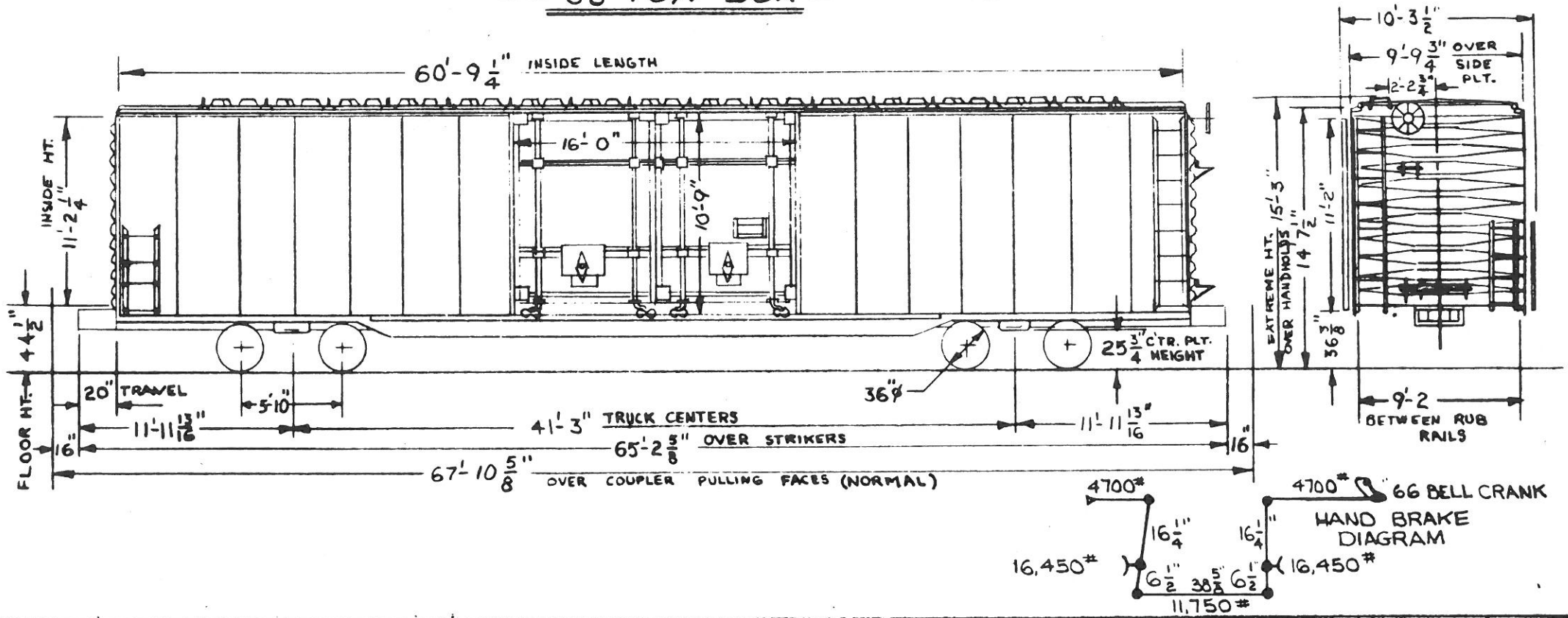

— GENERAL —		CYLINDER RELEASE VALVE: WESTINGHOUSE QRB	GENERAL DWG: SCULLIN 8308-(DT&I. W-9550)
BUILDER: GREENVILLE STEEL CAR CO.		DOORS AND FIXTURES: YOUNGSTOWN DOUBLE PLUG	JOURNALS: 6 1/2" X 12" ROLLER BEARINGS
YEAR BUILT: 1963		63-10852-H(DT&I DWG. V-6421)	JOURNAL BEARING: TIMKEN 6 1/2" X 12" 1-A
BUILDERS REF: O.Q. 817		OPENS FROM INSIDE OR OUTSIDE	SIDE BEARINGS: STUCKI 688-B(DT&I DWG. E-5817)
A.A.R. CLASS: X P		DRAFT GEAR: MINER A-22-XL	SIDE FRAME: AAR CODE-NONE SCULLIN PAT. NO. 7979-A
NO. BUILT: 30		DRAFT GEAR ATTACHMENTS: C.S. YOKE B-Y45	(DT&I DWG. V-9551) AAR IDENT. NO. 5010
CAPACITY: 6,000 CU. FT.		ENDS: STANRAY 5E-17736-B(DT&I DWG. V-6735)	NARROW PEDESTAL
AVE. LT. WT: 86,500 LBS.		TOP SHEET 3/16" BOTTOM SHEET 1/4"	SPRINGS: A.A.R. D-5, 14 OUTER, 12 INNER COILS PER TRUCK
AVE. LOAD LIMIT: 176,500 LBS.		END SILL: 6" X 3 1/2" X 5/16" ANGLE	DOUBLE BARBER SIDE SPRINGS(DWG. X-9426)
— BODY —		FLOOR: 2"-POTLATCH ELECTRO-LAM 1/4" FLOOR PLATE	TYPE OF TRUCK: 6 1/2" X 12" BARBER S-2-C STABILIZED
AIR BRAKE MFG: SECOND HAND		GENERAL DWG: GSC 20396 (DT&I V-6489)	NARROW PEDESTAL ROLLER BEARING
AIR BRAKE SCHEDULE: AB VALVE, NYCOPAC B3-8 1/2		HAND BRAKE: AJAX 14665 (REWORKED TO 1966)	WHEELS: 36" TWO WEAR WROUGHT STEEL J-36
UNITS - NO. N-8982		LINING: END:	
BODY CENTER PLATE: 13 3/4" CAST STEEL(DWG. W-9465)		SIDE: RUBRAILS 3/8" X 12" FLAT BAR	
BODY SIDE BEARING: HARDENED STEEL		ROOF: STANRAY 7R-17718-C (DT&I DWG. V-6733)	
CENTER SILL: SLIDING-2-2-26 @ 41.2#/FT.		SIDE PLATE: 6" ZEE @ 15.7#/FT. O.H.S.	
STATIONARY-13" @ 31.8#/FT. CHANNEL		SIDE SILL: 3" ZEE @ 6.7#/FT	
CENTER SILL AREA: SLIDING - 24.24 SQ. IN.		SIDE SILL REINFORCEMENT:	
STATIONARY - 18.60 SQ. IN.			
COUPLER: D-EGG-MT3 WITH VERTICAL ANGLE COCK		— TRUCK —	
BRACKET LEGS.		BOLSTER: A.A.R. CODE-NONE SCULLIN PAT. NO. 8264-A	
COUPLER RELEASE RIGGING: STANRAY 4U-17770-G		(DT&I DWG. W-9549) AAR IDENT. NO. 2072	
(DT&I DWG. V-6739)		BOLSTER CENTER PLATE WEAR PLATES: HORIZ. DWG. Y-9499	
CROSSOVER STEP: APEX 3950 (DT&I DWG. X-6593)		VERTICAL DWG. Y-9450	
CUSHIONING DEVICE: KEYSTONE 20' TRAVEL		BRAKE BEAM: N.Y.A.B #N-8977 (INCL. PISTON)	
		BRAKE SHOES: R.F.P. V-141	

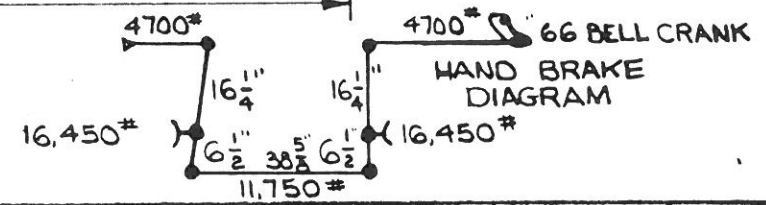

CARS: 25000-25049

D.T. & I.

MECHANICAL ENGINEERING DEPT. 1-29-70

— REVISIONS —

— 90 TON BOX —

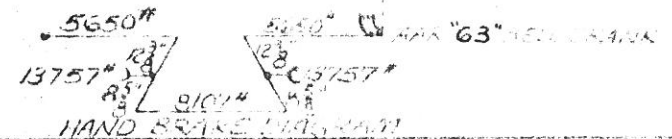
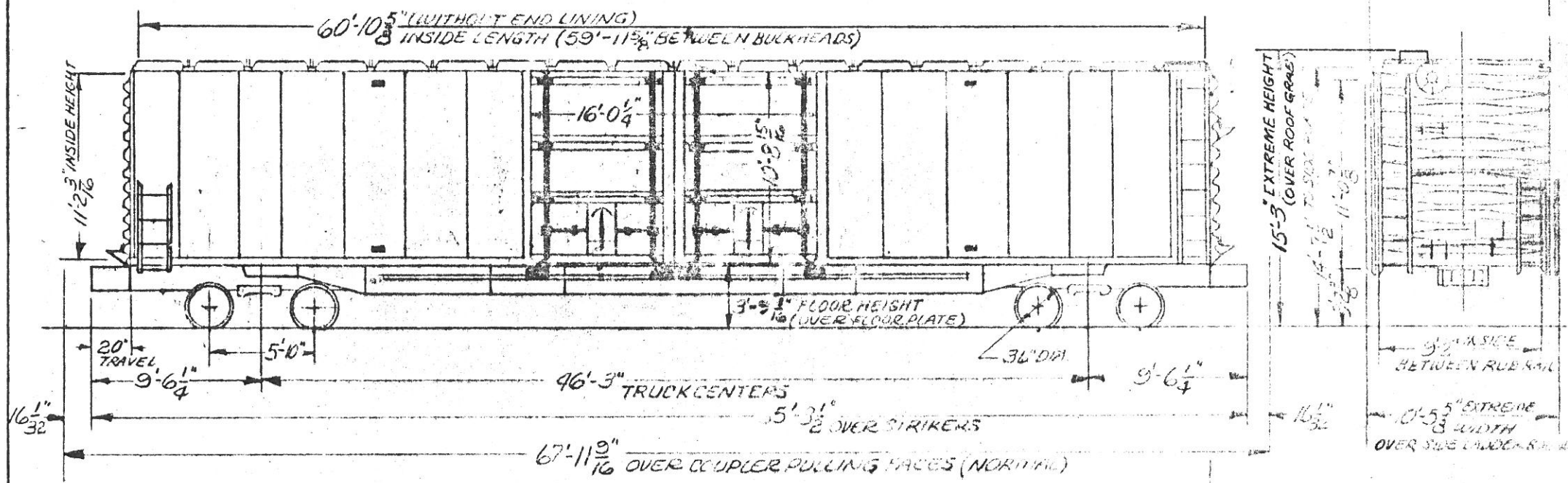

— GENERAL —		CYLINDER RELEASE VALVE: WESTINGHOUSE "GRB" DOORS AND FIXTURES: YOUNG'S PAT. 500,000 #16 (D.T. & I. DWG. 7011) (DOORS OPEN FROM INSIDE OR OUTSIDE) DRAFT GEAR M.V. R.R. # 53 (11000 CAPACITY) DRAFT GEAR AT ACME: IT. GRACE'S YOKES (B-Y45) ENDS: STD. RY. EQUIP. D. TOP SHEET #16 BOTTOM SHEET #14 END SILL: 6" X 3 1/2" X 3/8" ANGLE FLOOR: 2 1/4" DOWN LOC. 1/4" STL. PL. THRU DOORWAY GENERAL DRAWING: ACF FREIGHT SAVER (V-229) HAND BRAKE: MINER D-4290-XL (ON TRUCK ONLY) LINING: END: NONE SIDE: 5 RUB RAILS 1 1/2" X 3" FORMED CHANNEL ROOF: STD. RY. EQUIP. Q.	GENERAL DWG. NO. 25100-25179 JOURNALS: G. & L. CO. ROLLING JOURNAL BEARINGS: HYATT S. R. 3750 JOURNAL SCREW: MINER 30000 #10 (D.T. & I. DWG. 5849) SIDE BEARINGS: STEEL ROLLER #383 (D.T. & I. DWG. 2517) SIDE FRAME: CAST PATENT #10000 A. MARSHALL PEDISTAL LEAD: A.S. CODE #45-DIAM. 1/4" SPRINGS: 3" WHIPPLES PER TRUCK COILS PER TRUCK TYPE OF TRUCK: 100 TON FRISCHER 300 STABILIZED & EQUIPPED FOR ROLLER BEARINGS AND TRACK ROLLERS WHEELS: 36" 2 LIPS RAILROAD STEEL 1-36 FOR RAILROAD USE SEAL AXLES
BUILDER: AMERICAN CAR & FOUNDRY (ST. LOUIS) YEAR BUILT: 1964 BUILDERS REF: 11-06311 A.A.R. CLASS: XAP NO. BUILT: 80 CAPACITY: 6000 CU. FT. AVE. LT. WT.: 79,000 LBS (WITH OUT RACKS) AVE. LOAD LIMIT: 184,000 LBS	TRUCK CENTERS: 46'-3" OVER COUPLER PULLING FACES (NORMAL): 67'-11 9/16" OVER STRIKERS: 5'-3 1/2" FLOOR HEIGHT (OVER FLOOR PLATE): 3'-8 1/16" 36" DIA. 9'-6 1/4"		
— BODY —			
AIR BRAKE MFG. SECOND HAND AIR BRAKE SCHEDULE: STD. AS VALVE - WABCO PAC 8-3, 8Y UNITS BODY CENTER PLATE: 1 3/4" DROP FORGED KROPP FORGE DE 6036 BODY SIDE BEARING: DROP FORGED WEDGE SECTION CENTER SILL: SLIDING: 2 1/2" LAHT 41 2" FT. ROLLED ZEE SECT. STATIONARY: 5 1/2" PRESSED PLATE CENTER SILL AREA: SLIDING: 84.84 SQ. IN. STATIONARY: 12.78 SQ. IN. COUPLER: AAR B-6492B HT-TYPE E HEAD VERTICAL ANGLE COCK LUG TYPE F SHANK 43" PULLING (LINE TO DIA.) COUPLER RELEASE RIGGING: STD. RY. EQUIP. CO. (D.T. & I. DWG.) CROSS OVER STERS: U.S. GYRSUM "W" (2 FORGED) CUSHIONING DEVICE: ACF FREIGHT SAVER 20" TRAVEL	5650" 13757" 83" 9100" HAND BRAKE RIGGING	CARS: 25100-25179 D.T. & I. MOVING POWER: 169	
		1/66	

- 83 TON BOX -

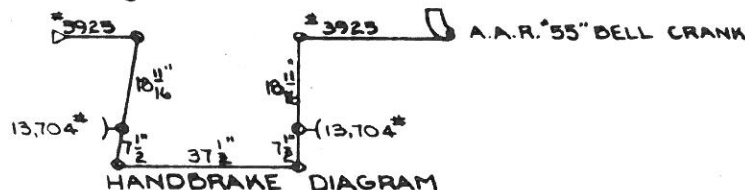
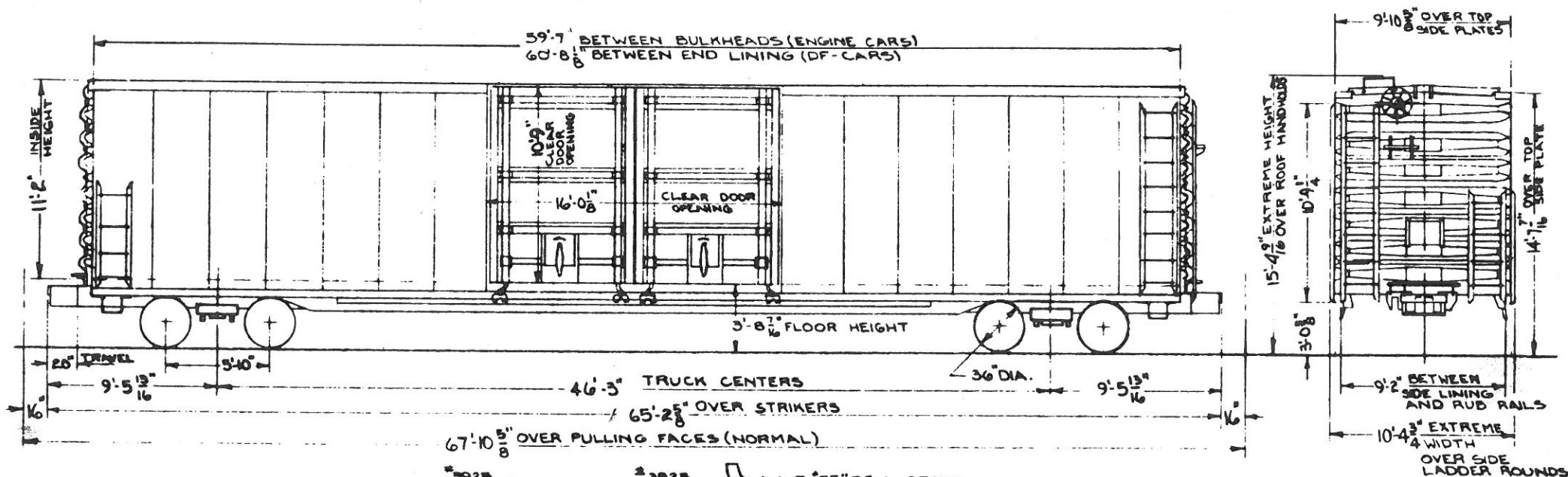

CARS 25200-25257 EQUIPPED WITH RUB RAILS AND END BULKHEADS FOR RACK LOADING
 CARS 25258-25314 EQUIPPED WITH COMPARTMENTIZERS AND DF-2 BELT RAILS FOR AUTO PARTS LOADING.

- GENERAL -		DOOR AND FIXTURES: YOUNGSTOWN-DOUBLE PLUG STEEL DOORS (OPEN FROM INSIDE OR OUTSIDE) DT&I DWG. V-8274	GENERAL DWG: A.S.F. 57597-A (DT&I DWG. X-6979)
BUILDER: GREENVILLE STEEL CAR CO.		DRAFT GEAR: MINER RF-333 (HIGH CAPACITY).	JOURNALS: 6 1/2" x 12" ROLLER BEARINGS
YEAR BUILT: 1965 & 1966		DRAFT GEAR ATTACHMENTS: GRADE "B" C.S. YOKE (B-Y45)	JOURNAL BEARINGS: BRENCO INC. 2583 - 65 1/2"
BUILDERS REF: 806		ENDS: STD. RWY. EQUIP. CO. - TOP SHEET 3/16", BOTTOM SHEET 1/2"	TIMKEN E-22237-Q - 50 1/2"
A.A.R. CLASS: XAP		END SILL: 6" x 3 1/2" x 5/16" ANGLE @ 9.8°/FT.	SIDE BEARINGS: STUCKI-DOUBLE ROLLER *688-B (DT&I DWG. Z-5817)
NO. BUILT: 115		FLOOR: 2" DOWELC. T&G WITH 3/16" PLT. IN DOORWAY.	SIDE FRAME: A.S.F. PATT. NO. 22032-A
CAPACITY: 6000 CU. FT.		2" DOWELC. 3/16" WEAR PLTS, OR 2 3/16" DOWELC. NO WEAR PLTS.	NARROW PEDESTAL JAW
25200-25257	25258-25314	GENERAL DWG. G.S.C. 31380 - (DT&I DWG. V-8279)	A.A.R. CODE F95-018N-UA
AVE. LT. WT.: 86,000 LBS.	95,400 LBS.	HANDBRAKE: AJAX CONSOLIDATED (DT&I DWG. W-8293)	A.A.R. IDEN. NO. 8-920 (DT&I DWG. W-812)
AVE. LOAD LIMIT: 177,000 LBS	167,600 LBS.	LINING: END 1 3/16" T&G (25258-25314)	SPRINGS: 3 1/16" A.A.R. "D5", 14 OUTER AND 14 INNER COILS PER TRUCK
- BODY -		SIDE 1 3/16" T&G (25258-25314)	TYPE OF TRUCK: 6 1/2" x 12" BARBER S-2-C
AIR BRAKE MFG.: WESTINGHOUSE		ROOF: STD. RWY. EQUIP. CO. 7R-19684-2 (DT&I DWG. V-8275)	STABILIZED, EQUIPPED FOR ROLLER BRGS AND TRUCK MTD. BRKS
AIR BRAKE SCHEDULE: ADD WABCO PAC B3 8 1/2" UNITS		SIDE SILL: 3" Z @ 6.7°/FT.	WHEELS: 36" 2 WEAR, WROT STEEL, J-36
BODY CENTER PLATE: 13 3/4" FABRICATED		SIDE BEARING CENTERS: 4'-2"	RAISED WHEEL SEAT.
BODY SIDE BEARING: DROP FORGED WEDGE SECT.		SIDE PLATE: 6" Z @ 15.7°/FT.	
CENTER SILL: SLIDING: 2 Z-26 @ 41.2°/FT. SECTIONS		SIDE SHEATHING: 110" C.B.S. RIVETED	
STATIONARY: 2 Z-26 @ 31.3°/FT. SECTIONS		- TRUCK -	
CENTER SILL AREA: SLIDING: 24.24 SQ. IN.		BOLSTER: NATIONAL CASTINGS PATT. #40936-59	
STATIONARY: 18.40 SQ. IN.		(DT&I DWG. V-8279) A.A.R. IDEN. NO. 8-1910	
COMPARTMENTIZER: EQUIP. CO. 57 CARS ONLY (DT&I DWG. V-8279)		A.A.R. CODE NO. NONE	
COUPLER: E68AHTS - BOTT. OPERATED		BRAKE BEAM: WAB. UNIT # 566247 (INCL. PISTON)	
COUPLER RELEASE RIG: STANRAY: 4U-17770 (V-6739)		BRAKE SHOES: COMPOSITION, R.F. PROD. V-141	
CROSSOVER STEP: U.S. GYPSUM CO. (DT&I DWG. V-8279)			
CUSHIONING DEVICE: "KEYSTONE" 20" TRAVEL			
			CARS: 25200 - 25314
			D.T. & I.
			MECHANICAL ENGINEERING DEPT. 12-30-65
			- REVISIONS -
			7/10 3/14